

# **S153 Ver.2 FUSION SPLICER**

## **User's Manual**

- Please read entire manual prior to usage.
- This manual must be kept with the S153 Fusion Splicer.

Issue 01

 **FURUKAWA ELECTRIC CO., LTD.**

---



## Contents

1.	Safety Information and Instructions.....	1-1
1.1.	Safety Information.....	1-1
1.2.	Safety Messages .....	1-1
1.3.	WARNINGS and CAUTIONS.....	1-3
1.4.	Power Requirements .....	1-11
1.5.	Toxic Hazards.....	1-12
1.5.1.	Incineration .....	1-13
1.5.2.	Acidic or caustic compounds.....	1-13
1.5.3.	Physical damage .....	1-13
2.	General Information .....	2-1
3.	Getting Started .....	3-1
3.1.	Unpacking and Initial Inspection .....	3-1
4.	Operating Specifications and Components .....	4-1
4.1.	Specifications .....	4-1
4.2.	Components.....	4-4
4.2.1.	Fiber Holder Type and Cleave Length .....	4-4
4.2.2.	Optional Components.....	4-6
4.3.	Optional Accessories .....	4-8
4.4.	Recommended Consumable .....	4-8
5.	External Description .....	5-1

5.1.	Main Body .....	5-1
5.2.	Operating Keys and Status LED .....	5-3
5.2.1.	Operating Keys.....	5-3
5.2.2.	LED Indicators .....	5-4
5.2.3.	Buzzer .....	5-5
5.3.	Screens .....	5-6
5.3.1.	Ready Screen.....	5-6
5.3.2.	Screen during Splice .....	5-7
5.3.3.	Status Icons .....	5-8
5.3.4.	Menu Screen .....	5-10
6.	Basic Operation.....	6-1
6.1.	Preparations for Power supply.....	6-1
6.1.1.	Installing Battery .....	6-1
6.1.2.	Connecting the power cable to AC adapter .....	6-4
6.1.3.	Charging the Battery .....	6-5
6.1.4.	Turn Splicer ON and OFF.....	6-7
6.2.	Installing programs.....	6-8
6.2.1.	Fusion Program .....	6-8
6.2.2.	Heat Program .....	6-10
6.2.3.	Selecting the Operating Language .....	6-12
7.	Fusion Splicing.....	7-1
7.1.	Basic Splicing.....	7-1

7.1.1.	Arc Check .....	7-1
7.1.2.	Preparing the Fiber.....	7-4
7.1.3.	Loading the Fiber .....	7-5
7.1.4.	Fusion Splicing .....	7-6
7.1.5.	Splicing Defects.....	7-10
7.1.6.	Removing the Spliced Fiber .....	7-12
7.1.7.	Reinforcing the Fusion Splice.....	7-13
8.	Programming Guide .....	8-1
8.1.	Programming Functions and Menu.....	8-1
8.2.	Program Edit .....	8-7
8.2.1.	Setting .....	8-8
8.2.2.	Detail Setting .....	8-9
8.2.3.	Default .....	8-10
8.2.4.	Copy .....	8-11
8.2.5.	Delete .....	8-11
8.2.6.	Edit Comment.....	8-12
8.2.7.	Parameter Table .....	8-14
8.3.	History .....	8-22
8.3.1.	Splice Data .....	8-23
8.3.2.	Arc Check History.....	8-27
8.3.3.	Image Capture.....	8-29
8.4.	Tool.....	8-32

8.4.1.	Machine Check.....	8-33
8.4.2.	Fiber Measuring .....	8-34
8.4.3.	Environment .....	8-36
8.4.4.	Manual Splicing .....	8-37
8.4.5.	Image Capture.....	8-40
8.4.6.	Adjusting shrinking condition of sleeve .....	8-41
8.5.	Setting .....	8-42
8.5.1.	Parameter.....	8-45
8.5.2.	Counter.....	8-55
8.5.3.	Data .....	8-56
8.5.4.	Clock.....	8-58
8.5.5.	About Machine .....	8-58
8.6.	Shortcut.....	8-59
8.7.	Maintenance.....	8-60
9.	Maintenance and Handling Instructions .....	9-1
9.1.	Error Messages.....	9-1
9.2.	Maintenance.....	9-6
9.2.1.	Arc Check.....	9-6
9.2.2.	Electrode Maintenance.....	9-6
9.2.3.	Cleaning the objective lens .....	9-9
9.2.4.	Cleaning the V-grooves.....	9-9
9.2.5.	Cleaning the V-groove Fiber Clamps .....	9-10

9.2.6.	Cleaning the Tight-holder and Fiber-holder .....	9-10
9.3.	Back up battery .....	9-11
9.4.	Storing and Shipping .....	9-11
9.5.	Claims and Repackaging .....	9-12
9.6.	Return Shipments to Furukawa Electric Co. ....	9-12
10.	Option .....	10-1
10.1.	Battery Charger : S958C .....	10-1
10.2.	Cooling Tray : CTX-01 .....	10-4
10.3.	Working Belt : WBT-01 .....	10-5
10.4.	Cleaning Brush : VGC-01 .....	10-6
10.5.	Hard carrying case : HCC-01 .....	10-7
10.6.	Tripod adaptor : TPA-01 .....	10-8
11.	Recycling and Disposal.....	11-1





## 1. Safety Information and Instructions

This manual contains complete operating and maintenance instructions for THE S153 Ver.2 FUSION SPLICER. Please review this manual carefully before operating.

### 1.1. Safety Information

---

The following safety instructions must be observed whenever the S153 Ver.2 fusion splicer is operated, serviced or repaired. Failure to comply with any of these instructions or with any precaution or warning contained in the User's Manual is in direct violation of the standards of design, manufacture and intended use of the instrument. Furukawa Electric Co., Ltd. assumes no liability for the customer's failure to comply with these safety requirements.

### 1.2. Safety Messages

---

The following messages may appear in the User's Manual. Please observe all safety instructions that are associated with the message.

## Safety Information and Instructions

---

	Refer to the User's Manual for instructions on handling and operating the instrument safely.
WARNING	The procedure can result in serious injury or loss of life if not carried out in proper compliance with all safety instructions. Ensure that all conditions necessary for safe handling and operation are met before proceeding.
CAUTION	The procedure can result in serious damage to or destruction of the instrument if not carried out in compliance with all instructions for proper use. Ensure that all conditions necessary for safe handling and operation are met before proceeding.

- ◆ Please contact Furukawa Electric Co., Ltd. or your local representative with any questions relating to any subjects described within this manual.

In no case will Furukawa Electric Co., Ltd. be liable to the buyer, or to any third parties, for any consequential or indirect damage which is caused by product failure, malfunction, or any other problem.

### 1.3. WARNINGS and CAUTIONS

---



## WARNING

- ◆ This is a Class A product of EN 55022(1998). In a domestic environment this product may cause radio interference in which case the user may be required to take adequate measures.
- ◆ The power cord supplied with this equipment must be connected to a power socket, which provides a reliable protective earth. Or, ground it with the Ground terminal on the fusion splicer.
- ◆ Use only the cords attached to the fusion splicer. Connecting inappropriate cords or extending the cords may cause them to heat up abnormally and may cause fire.
- ◆ This product contains a Lithium Cell. The device is identified by a warning label. Do not dispose of in fire. Disposal of this device must be carried out by qualified personnel.



# WARNING

- ◆ Never touch the electrodes when the fusion splicer is powered on. Doing so may cause electrical shock. ⚠ Warning symbol is placed on the windshield to notify it.
- ◆ Do not operate the fusion splicer without electrodes.
- ◆ Do not disassemble the instrument except as described in the maintenance section of this manual. The fusion splicer contains no user serviceable parts. Warranty on this product will be invalidated if any of the potted nuts are disturbed.
- ◆ Avoid soaking the fusion splicer with water. Doing so may cause fire, electrical shock or malfunction.
- ◆ Do not use inappropriate input voltage. Doing so may cause fire, electrical shock or malfunction.
- ◆ Do not insert or drop any metal or any flammable material into the main body through any aperture. Doing so may cause fire, electrical shock or malfunction.
- ◆ Avoid direct skin contact with the heating portion. This may cause burn or injury. ⚠ Warning symbol is placed on a lid of the protection sleeve heater to notify it.



## WARNING

- ◆ Do not remove the panels of the fusion splicer. Some parts generate high voltage. Removing the panels may cause electrical shock.
- ◆ If abnormal sounds or extra high temperatures are observed, turn off the power, disconnect the power cord, remove the battery from the fusion splicer and contact Furukawa Electric Co., Ltd. or your local representative. Continuing to operate under these conditions may cause fire or electrical shock.
- ◆ Do not use a damaged power cord where the inner cable is exposed or severed. Doing so may cause fire or electrical shock.
- ◆ If water is spilled into the fusion splicer, turn off the power switch, disconnect the power cord, remove the battery and contact Furukawa Electric Co., Ltd. or your local representative. Continuing to operate under these conditions may cause fire or electrical shock.



# WARNING

- ◆ If smoke or strange smells are observed, turn off the power switch, disconnect the power cord, remove the battery and contact Furukawa Electric Co., Ltd. or your local representative. Continuing to operate under these conditions may cause fire, electrical shock or malfunction.
- ◆ If the fusion splicer is dropped and damaged, turn off the power switch, disconnect the power cable, remove the battery and contact Furukawa Electric Co., Ltd. or your local representative. Continuing to operate may cause fire or electrical shock.
- ◆ Do not look into a fiber with naked eye during operation. Wearing a protection glass is recommended.
- ◆ STOP using the fusion splicer when problems are experienced with the protection sleeve heater. Turn off the power immediately, remove the battery and contact service center.



# WARNING

- ◆ The S153 Ver.2 passed the following test conditions:

Drop resistance – 76cm drop from 5 different angles \*. Water resistance – IPX2 rating drip proof (exposed to 3mm/min drip for 10 min with 15° tilt) \*. Dust resistance – IP5X rating dust proof (exposed to dust particles with a diameter of 0.1 to 25µm for 8 hours) \*

\*Above tests were performed at Furukawa Electric Co., Ltd laboratories and do not guarantee that the machine will not be damaged when subjected to these conditions.

## Safety Information and Instructions

---

The S943B Battery is made of Li-ion battery cells. Refer to following safety instructions on handling and operating the Battery safely.



# WARNING

- ◆ Do not dispose the Battery in fire, or leave the Battery near a high-temperature object. Doing so may cause fire or explosion.
- ◆ Do not short-circuit the recharging connector or the output terminal for splicer. Doing so may cause fire by generation of heat.
- ◆ Charge the S943B Battery by the S153 or S958C Battery Charger. If charging by other equipment that is not suitable for charging S943B, it may cause fire.
- ◆ Avoid soaking the Battery with water. Doing so may cause fire or electrical shock.
- ◆ Do not disassemble the Battery. Avoid damage by dropping or heavy shock. Doing so may cause fire or electrical shock. If inner cells rupture and electrolytic solution leaks outside, it may cause inflammation to your skin or eyes.
- ◆ Disposal of used Battery must be carried out according to disposal established by Law. For instructions, contact Furukawa Electric Co., Ltd. or your local representative.





# CAUTION

- ◆ Do not place the fusion splicer on an unstable or inclined surface. There is a possibility that the fusion splicer will fall and cause injury.
- ◆ Disconnect all cords when moving the fusion splicer. Failure to do so may damage the cords which may cause fire or electrical shock.
- ◆ Do not place the cords around any heating instrument. Doing so may damage the cords which cause fire or electrical shock.
- ◆ Do not connect or disconnect cords with wet hands. Doing so may cause fire or electrical shock.
- ◆ Do not pull the cord to disconnect. Doing so may damage the cords which may cause fire or electrical shock. Hold the plug portion and disconnect the cord.
- ◆ Do not put heavy items on the cords. Doing so may damage the cords which may cause fire or electrical shock.
- ◆ Do not modify the cords and do not over-bend, over-twist, or over-stretch the cords.

## Safety Information and Instructions

---

Doing so may cause fire or electrical shock.

- ◆ Ensure that the cords are disconnected and the batteries are removed from machine's main body when storing the fusion splicer.
- ◆ Never use aerosol dust cleaners or alcohol-based solvents to clean the electrodes.
- ◆ Non oil-based solvents should be used to clean the optical lenses.
- ◆ Store the fusion splicer in a cool dry place.

## **1.4. Power Requirements**

---

The S153 Ver.2 fusion splicer can operate from any single-phase AC power source that supplies between 100-240 V at a frequency of 50-60 Hz with the S976A\_AC adapter. It also has the S943B internal battery for battery operation and the battery can be charged in the S958C unit by the AC power source through the S976A\_AC adapter or S977A\_AC\_adapter. It can also be charged while it is inserted in the splicer's body.

 <b>WARNING</b>	<p>To avoid the risk of injury or death, <b>ALWAYS</b> observe the following precautions before initializing the S153 Ver.2 fusion splicer.</p> <ul style="list-style-type: none"><li>◆ Do not connect both AC and DC power sources at the same time (Connect one source or the other).</li><li>◆ If using a voltage-reducing auto-transformer to power the S153 Ver.2 fusion splicer, ensure that the common terminal connects to the earthed pole of the power source.</li><li>◆ Use only the type of power cord supplied with the S153 Ver.2 fusion splicer.</li><li>◆ Connect the power cord to a power outlet equipped with a protective earth contact only (never connect to an extension cord that is not equipped with this feature).</li><li>◆ Willfully interrupting the protective earth connection is prohibited.</li></ul>
---	---

## 1.5. Toxic Hazards

---

The S153 Ver.2 fusion splicer presents no toxic hazards (under normal conditions of use, storage, and handling). However, under the following conditions, certain precautions are necessary.

---

### **1.5.1. Incineration**

Some of the electronic components included in the assembly are constructed with resins and other chemicals that produce toxic fumes during incineration.

### **1.5.2. Acidic or caustic compounds**

Some of the electronic components included in the assembly, particularly electrolytic capacitors, contain acidic or caustic compounds. In the event that a damaged component comes in contact with the skin, wash the affected area immediately with cold water. In the event of eye contamination, irrigate thoroughly with a recognized eye-wash and seek medical assistance.

### **1.5.3. Physical damage**

Some of the components used in the assembly may contain very small quantities of toxic materials. There is a remote possibility that physically damaged electronic components may present a toxic hazard. As a general precaution, avoid unnecessary contact with damaged electronic components, and arrange for disposal in accordance with local regulations.



## 2. General Information

Fusion splicing is used to physically join together two optical fiber ends. The process may vary, depending on the type of fusion splicer used. The S153 Ver.2 Single-Fiber Fusion Splicer has an active cladding aligning mechanism to align the fiber ends, and a controllable electric arc to melt the glass and butt the ends together. This results in a strong joint, with low loss and low back-reflection.

To achieve good splicing results, it is essential to know both the proper use of a fusion splicer and the characteristics of optical fiber. Because all fibers are not identical, they can melt or fuse at different temperatures. Therefore, to minimize splice loss, it is important that the arc power and the duration of the fusion arc be properly adjusted. The S153 Ver.2 fusion splicer features an arc function inspection to help the user adjust these parameters.

Other intrinsic factors that contribute to the increase in splice loss are core diameter mismatch, cladding diameter mismatch, numerical aperture mismatch, core concentricity and non-circularity.

### Core Diameter Mismatch

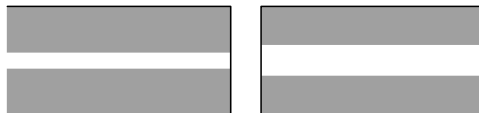

### Cladding Diameter Mismatch

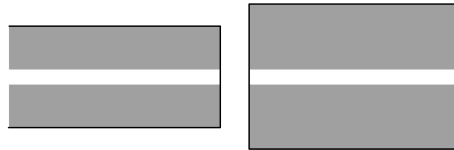

### Numerical Aperture Mismatch

Different fibers have different numerical apertures. The aperture dictates the acceptance angle of light.

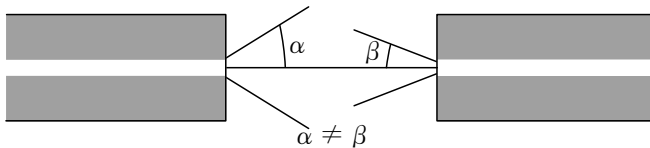



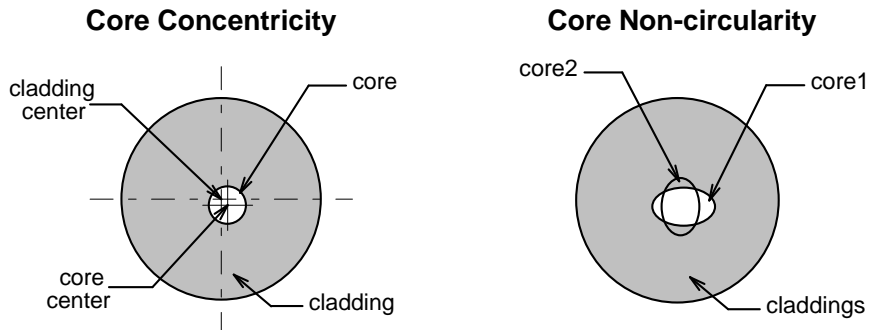

Optical fiber is basically classified as either single-mode (SM) or multi-mode (MM). Single-mode fiber, which includes dispersion-shifted

fiber types, will transmit a single-mode (path) of data at wavelengths greater than the cut-off wavelength (1170 nm). Approximately 80% of the light is transmitted within the core, and 20% is transmitted in the surrounding cladding. Therefore, the transmission path is more accurately referred to as the mode field and not as the core. With a core diameter of typically 8  $\mu\text{m}$  and a mode field diameter of approximately 10  $\mu\text{m}$ , single-mode fiber can transmit more data than multi-mode fiber and with less attenuation.

In multi-mode fiber, the optical signal is transmitted entirely within the core. These fibers have a core size of 50  $\mu\text{m}$  to 100  $\mu\text{m}$  (50  $\mu\text{m}$  or 62.5  $\mu\text{m}$ , typically) and are commonly used in local area networks (LANs), short distance links and closed circuit television (CCTV).

**Physical Characteristics of Optical Fiber for Fusion Splicing**

<b>Coating</b> standard diameter material	250 $\mu\text{m}$ , 900 $\mu\text{m}$ acrylic resin, nylon
<b>Cladding</b> standard diameter material	125 $\mu\text{m}$ silica, Fluoro doped silica, Titan-coated silica
<b>Core</b> standard diameter material	8 $\mu\text{m}$ – 10 $\mu\text{m}$ (SM) 50 $\mu\text{m}$ – 62.5 $\mu\text{m}$ (MM) Germanium doped silica, silica

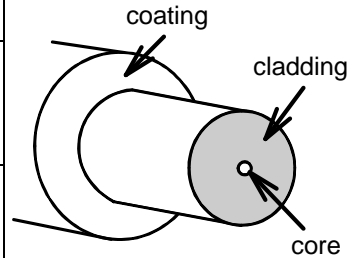

**Fiber Transmission**

	Non-zero Dispersion shifted	Dispersion shifted	Single mode	Multi mode
Transmitting capacity	superior	superior	high	low
Splice loss	high	high	middle	very low
Splicing ease	difficult	difficult	middle	easy

### Physical Characteristics of Single-mode and Multimode Fiber

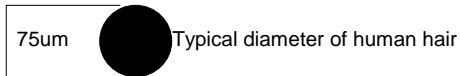
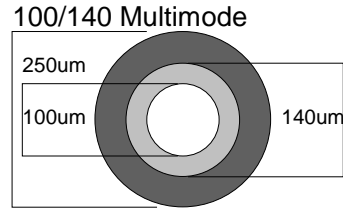
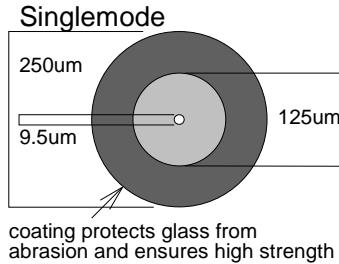
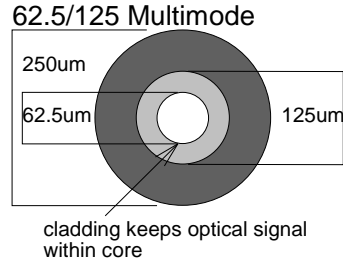
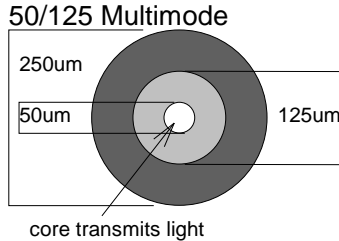



## 3. Getting Started

### 3.1. Unpacking and Initial Inspection

---

1. Inspect the shipping container for any indication of excessive shock to the contents.
2. Remove the S153 Ver.2 carrying case from the shipping container, and open the case. Ensure that the carrying case is right side up before opening.(It applies in the package form with the carrying case.)
3. Inspect the contents to ensure that the shipment is complete.
4. Place the S153 Ver.2 fusion splicer on a flat, smooth surface.
5. Visually inspect the S153 Ver.2 fusion splicer and all accompanying components for structural damage that may have occurred during shipping.

Immediately inform Furukawa Electric and the carrier, if the contents of the shipment are incomplete, or if any of the S153 Ver.2 fusion splicer components are damaged/defective, or if the S153 Ver.2 fusion splicer does not pass the initial inspection.

- ◆ *Protection sheet is pasted on the surface of LCD cover, the surface of the switch panel, and the surface of the label. Please peel off before using S153 Ver.2.*



**WARNING**

To avoid electrical shock, do not initialize or operate the S153 Ver.2 fusion splicer if it bears any sign of damage to any portion of its exterior surface, such as the outer cover or panels.

## 4. Operating Specifications and Components

### 4.1. Specifications

Item	Specification and Features
Applicable Fibers	SMF/MMF/DSF/NZDSF/BIF
Fiber cleave length	5-16mm for 250um fiber, 10-16mm for 900um fiber tight buffer
Clad diameter	0.125mm
Coating diameter	0.25 – 1.0mm
Typical Insertion Loss (similar fiber splicing)	0.04dB for SMF, 0.02dB for MMF, 0.06dB for DSF,
Splice programs	Up to 150
Heat programs	Up to 18
Dimension	127W × 199D × 105H[mm](Not including shock absorber) 159W × 231D × 130H[mm](Including shock absorber)
Weight	1.7kg(Without battery), 2.1kg(With 2 batteries)

## Operating Specifications and Components

---

Item	Specification and Features
Fiber Holding	Tight Holder Loose tube applicable or Fiber Holder System
Splice time*1	10.5sec (semi auto mode*2), 12.5sec (regular mode)
Applicable Sleeves	20 / 25 / 35 / 40 / 60 mm
Heating time*3 (In the AC adaptor use)	26sec for 40mm and 60mm sleeves (Pre-heating mode), 21sec for 20mm
Return Loss	>60dB
Tension Test	1.96N
Monitor	3.5" color LCD monitor
Video output Data interface	USB 2.0
Splice memory	Max 2000 splices
Image capture capacity	Last 100 images to be automatically captured + Up to 24 images to be stored permanently
Display user interface	GUI
Battery capacity*4	90 splice/heat cycle with single battery and 250 splice/heat cycle with dual batteries
Displaying language	21 languages (e.g. English, Spanish, Japanese, Chinese)



## Operating Specifications and Components

---

Item	Specification and Features
Operating temperature	-10 to +50 degree C (without excessive humidity)
Storage temperature	-40 to +60 degree C (without excessive humidity)
Power source	AC 100 to 240V (50/60Hz), DC Input 11 to 17V

- \*1: It is a splicing in the common temperature by "Fusion Program No.1". They are mean values of ten splicing except the first splicing and the splicing after the error.
- \*2: In the Semi-auto mode, fiber on both sides moves forward to near the splicing point automatically by shutting the windshield.  
When the machine parameter "Auto mode" is set to "Semi Auto", Semi\_auto function is effective.
- \*3: In the battery use case, the heating time might be longer than typical heating time. The heating time might be longer depending on the environment too.
- \*4: It is operated in room temperature with "Fusion\_program No.002", "Heater\_Program No.002", "Battery\_mode Parallel", and with new batteries.

## 4.2. Components

---

### 4.2.1. Fiber Holder Type and Cleave Length

The S153 Ver.2 Splicer comes with the following Fiber Holder Types, depending on the ordering number. S153A-3-X Fiber Holder System does not include the Fiber Holder (this is optional equipment).

Fiber Holder Type	Cleave Length	Ordering Number
16mm Tight Holder (S712T-016)	5-16mm (125/250 $\mu$ m) 16mm (125/900 $\mu$ m)	S153AE-1-X*Y*1
10mm Tight Holder (S712T-010)	5-10mm (125/250 $\mu$ m) 10mm (125/900 $\mu$ m) Loose Tube (125/250 $\mu$ m)	S153AE-2- X*Y*1
Fiber Holder System	10mm (125/250-900 $\mu$ m)	S153AE-3- X*Y*1

\* X=1 or 2, 1=Hard Carrying case, 2=UNIFLO PAX

\* Y=0, 1 or 2, It means number of battery pack.

## Operating Specifications and Components

---

### Standard Components

The S153 Fusion Splicer comes with the following standard equipment. Be sure to confirm their presence before starting any operation.

Part	Part Number	Quantity
Splicer Main Body	S153A-X-A-0001	1
Cleaning Brush	VGC-01	1
Spare Electrode	S969	1 pair
Electrodes Sharpener	D5111	1
Hard Carrying Case*	HCC-01	Depending on the package
Battery	S943B	Depending on the package
AC Adapter for Splicer	S976A	1
User Manual	FTS-B351	1
Tight holder	S712T-L-16(10) S712T-R-16(10)	Depending on the package

\*1) Close the lid of protection sleeve heater, when you store the splicer in the carrying case. When transported, the lid of heater might be damaged.

## 4.2.2. Optional Components

Item	Part Number	Quantity
Cooling Tray	CTX-01	1
USB Cable	USB-01	1
Soft Carrying Case*1	SCC-01	1
Working Belt	WBT-01	1
Car Cigarette Cable*2	CDC-01	1
Angle Stand	AGS-01	1
AC Adapter for Battery Charger	S977A	1
Battery Charger	S958C	1
Tripod adaptor	TPA-01	1
Tight Holder for 16mm Cleaving length	S712T-016	1 pair
Tight Holder for 10mm Cleaving length	S712T-010	1 pair
Fiber Holder for 250um coating diameter fiber	S712S-250	1 pair

## Operating Specifications and Components

---

<b>Item</b>	<b>Part Number</b>	<b>Quantity</b>
Fiber Holder for 500um coating diameter fiber	S712S-500	1 pair
Fiber Holder for 900um coating diameter fiber	S712S-900	1 pair

- \*1) Please do not give a big impact when you carry with Soft carrying case or Working belt. The storage thing might be damaged by the impact. Soft carrying case and Working belt don't guarantee protection from the fall and the impact.
- \*2) FUSE: 125V-7A Normal

### **4.3. Optional Accessories**

---

Contact furukawa Electric Co., Ltd. or your local representative for a more detailed specification.

- S210 Stripper
- S218R Hot Stripper
- S219 Hot Stripper
- S325 High Precision Cleaver
- S921 60mm Splice Length Protection Sleeves
- S922 40mm Splice Length Protection Sleeves
- S928A20, 25, 35 Mini Sleeves

### **4.4. Recommended Consumable**

---

Keep a supply of the following items with the S153 Ver.2 fusion splicer at all times.

- Tweezers
- Protective eye glasses
- Denatured alcohol
- Lint-free tissues or swabs
- Container for disposal of scrap fiber

## 5. External Description

### 5.1. Main Body

---

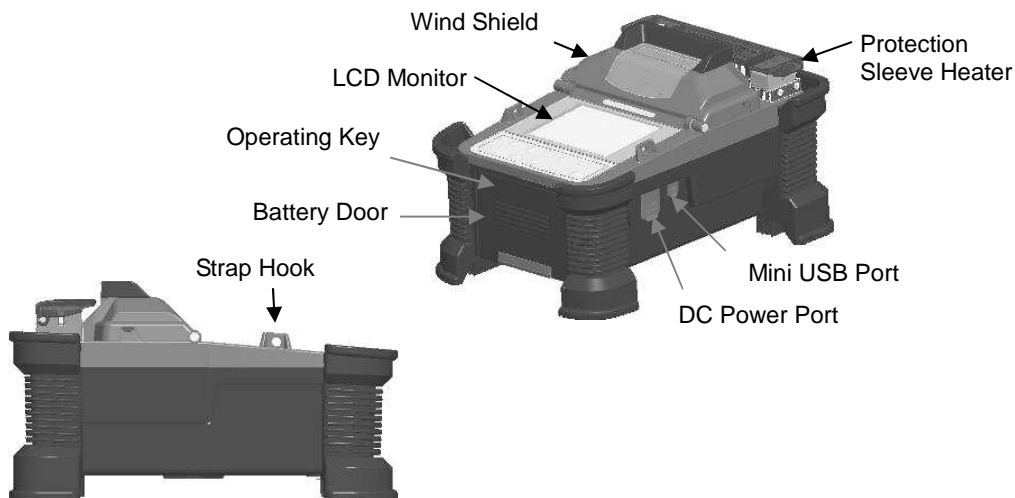

## External Description

---

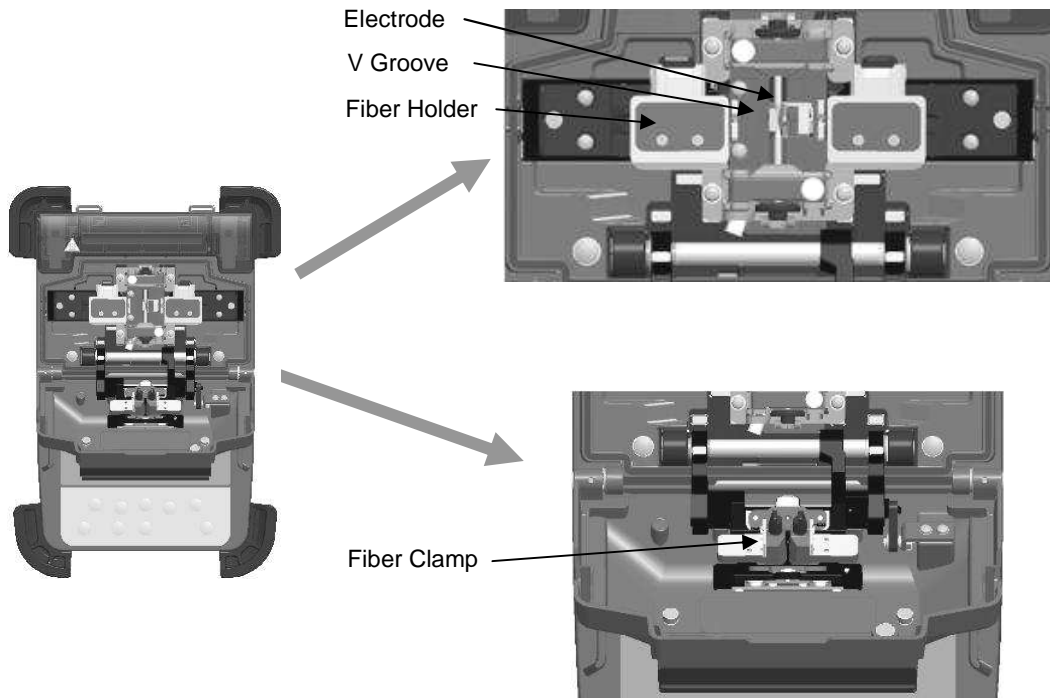







## 5.2. Operating Keys and Status LED

---



### 5.2.1. Operating Keys



Indicator	Name	Main functions
	Start	Start/Pause/Restart the splicing process/Page feed
	Function 1	Selecting the function(s) shown on right bottom corner of LCD.
	Function 2	Selecting the function(s) shown on left bottom corner of LCD.
	Up	Move upward/ Increase value/ Add additional arc
	Down	Move downward/ Reduce value LCD Brightness control when Ready status

Indicator	Name	Main functions
	Left	Move left
	Right	Move right
	Heating	Start heating / Stop heating
	Power	Turn on/off the power

### 5.2.2. LED Indicators

Indicator	Name	Color	State
	Power LED	Green	Lit : Tuned on Blinking : Sleep mode
	Heater LED	Red	Lit : During heat Blinking : During cool

### **5.2.3. Buzzer**

Buzzer will ring whenever any key is pressed. In addition, the following buzzer patterns indicate status of operation.

- Operating key: one beep
- Completing machine reset: one beep
- Error occurred: three beeps
- Splicing finished: a series of beeps
- Saving data: two beeps
- Heating process finished: one long beep

## 5.3. Screens

---

### 5.3.1. Ready Screen

Once the S153 Ver.2 fusion splicer is powered up and initialized, the “Ready” screen is displayed.

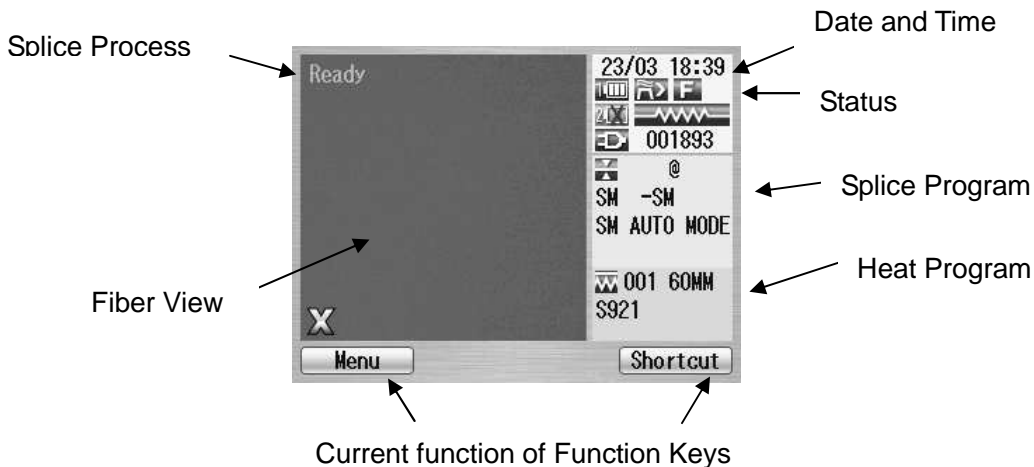

### 5.3.2. Screen during Splice

Simple GOOD/BAD icon  
Green indicates good splicing,  
and red indicates bad splicing.

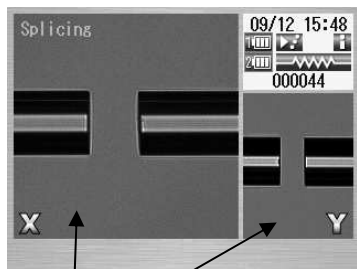











Fiber Images  
X from front camera and Y from  
back camera. X and Y views  
can be replaced.











Pop-up Window  
Pop-up when new functions  
are selected. Also, shows  
warning and error messages.



### 5.3.3. Status Icons

Type	Icon	Content
Power		Using external power
		Using internal battery. The level of battery has four stages. The lamp will start to flash when the level is very low. When using 2 batteries, the state of each battery is indicated. The icon is changed to red from blue when using battery.
		
		
		
	No battery	
		Charging (Batter mark is displayed in red.)
Back-up battery warning		The lamp will be “on” when back-up battery (for storing parameters and data) is very low.
Heater Status		Blue : In ready mode. Red : In heating mode. Orange: In preliminary heating mode.
		In cooling mode. *)

## External Description

Type	Icon	Content
		Error occurring.
Running mode		In this mode, splicing is triggered by closing the wind shield.
		Splicing process goes on until the end of splicing
		Splicing process pauses once before arc discharge.
		Splicing process pauses at each sub-step.
		In this mode, splicing is triggered by closing wind shield and then pressing the Start key.
		Splicing process goes on until the end of splicing
		Splicing process pauses once before arc discharge.
		Splicing process pauses at each sub-step.
		Semi-Auto mode is effective. The fiber is loaded to the center of the screen by closing windshield, and stops temporarily. Splicing is triggered by pressing the Start key.
Data output		In this mode, various measurement and calculation information is shown on the fiber image area.

\*) The heater cooling fan pauses regardless of the its icon status, when heating and splicing are done at the same time. Splicing is completed, the cooling fan works again.

### 5.3.4. Menu Screen



Press ◀ ▶ and ▲ ▼ keys to access to the desired menu and the pointed menu pop-ups to large icon. Press **Enter** to select the menu.

Function keys are provided to initiate current available functions displayed above the function keys.



## External Description

---

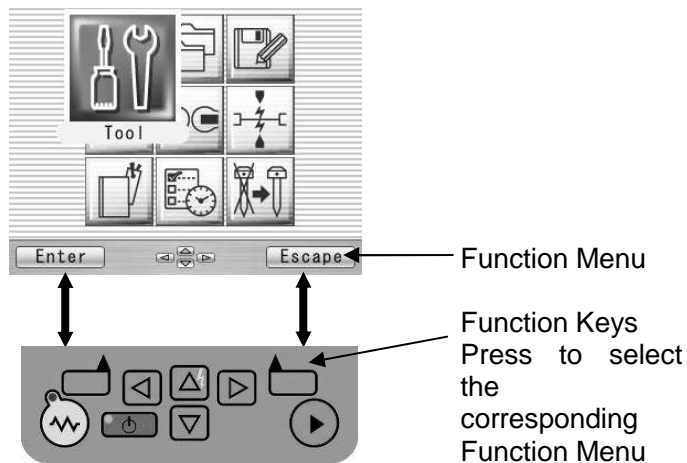



## 6. Basic Operation

### 6.1. Preparations for Power supply

---

#### 6.1.1. Installing Battery



#### **CAUTION**

- Turn off the power before doing any operation.
- Do not drop the battery during the installing or removing operation.



If the battery level indicator on the right upper corner is flashing, it means the battery is running out. Please swiftly plug the power cable and start the charge process.

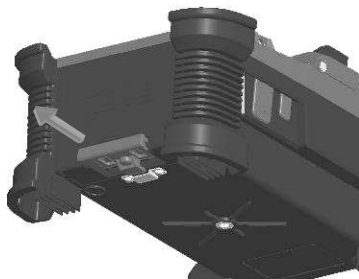

1. Pull the Battery Door Lock.

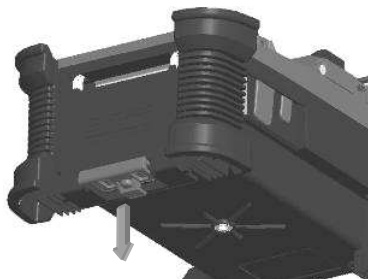

2. Lower the Battery Door a little.

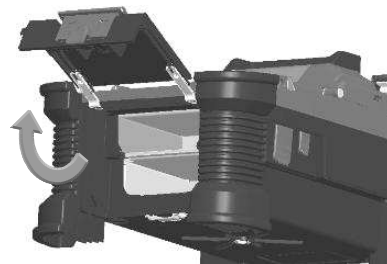

3. Open the Battery Door Lock.

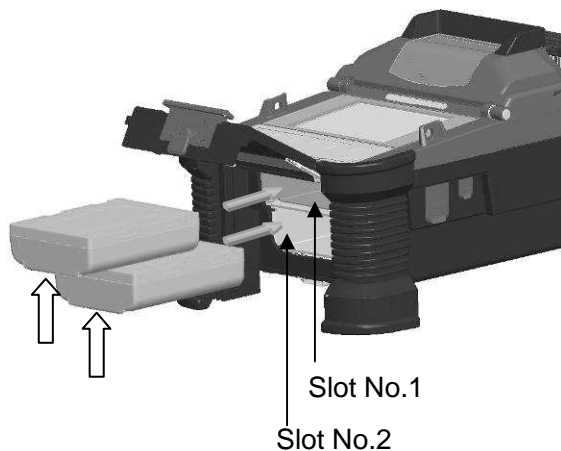

4. Insert the battery straight in the battery slot of the fusion splicer in the correct direction.

After closing the battery door, lock the door lock surely

Even if two pieces are put or only one piece is put in the upper or the lower, the battery can be used.

How to detach the battery is a procedure opposite to the installation. Hang your finger on the arrow part, and pull out battery from slot.



Don't pull out the battery when power is turned on.  
The power supply might fall.

## 6.1.2. Connecting the power cable to AC adaptor

Connect the AC adaptor to DC Power port of the Splicer, and plug the AC adaptor into AC outlet.

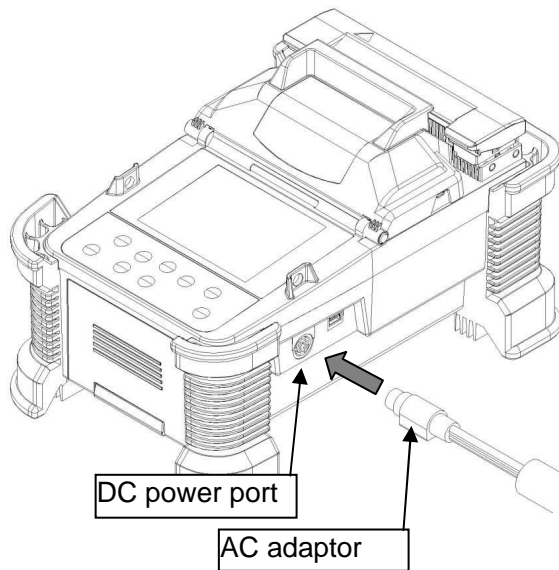

### 6.1.3. Charging the Battery

When charging battery in the S153 Ver.2 splicer

1. After connecting the power cable to AC adapter and plugging the power cable into AC outlet, Turn the splicer on. Charging process starts.

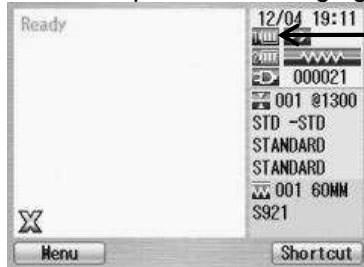



Charging battery indicator is red.

When charging battery with external charger

Follow the procedure below to charge the S943B battery.

1. Place the S958C Charger on a flat surface and connect to AC power source with AC adapter. When a power supply is connected, the power lamp turns on green steady light.
2. Insert the S943B battery to charge slot on the S958C charger. 2 batteries can be inserted in the S958C charger. The S958C charger charges with two batteries at the same time.
3. The red light on the S958C charger illuminates while recharging. It takes approximately 2 hours to recharge an empty battery.
4. The light changes to green when the recharge is completed. Remove the S943B battery.

5. Disconnect the S958C charger from AC power source.

	<p>S943B battery is lithium ion type rechargeable battery; it can be recharged at any time, regardless if it is fully empty or still with some residual power.</p> <p>If storing battery for a long time, the power level becomes very low caused by self-discharging and the battery may be degraded. Be sure to recharge the battery at least every 2 months even when not in use.</p>
	<p>It is possible that the battery could not be fully charged, if moving the battery from a cold place (&lt;math&gt;&lt;5^{\circ}\text{C}&lt;/math&gt;) to a warm place (around <math&gt;20^{\circ}\text{c}&lt; a="" and="" battery="" battery.<="" case,="" charge="" charging="" environment="" equalize="" for="" immediately="" in="" is="" it.="" make="" math&gt;)="" new="" p="" short="" sure="" temperature,="" the="" then="" this="" to="" while=""><p>When charging battery, the room temperature must be in the range of 5 - <math&gt;40^{\circ}\text{c}&lt; math&gt;.<="" p=""></math&gt;40^{\circ}\text{c}&lt;></p></math&gt;20^{\circ}\text{c}&lt;></p>



## 6.1.4. Turn Splicer ON and OFF

Turning ON/OFF the power : Keep pushing power key (for about 2 seconds)



### Turning ON power

The opening message will appear on the LCD screen for a short while, before the ready screen showing up.

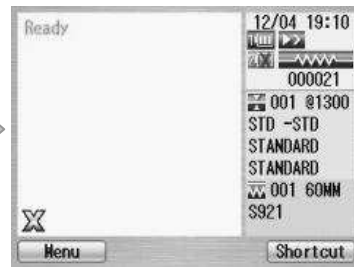

### Turning OFF power

The LCD screen is turned off.  
The power supply cuts after all motors perform the reset operation.

## 6.2. Installing programs

---

Load appropriate programs before operation. The S153 Ver.2 fusion splicer already has pre-defined programs installed for most commonly used fiber types and protection sleeves as default programs. User can select the program for fusion and heat, or edit and store it to a new program slot.

### 6.2.1. Fusion Program

Load the appropriate fusion program for the specific fibers to be spliced.

1. Select “Fusion PRGM” and press **Enter** Key to display the Fusion PRGM screen.
2. Select “Recent Programs” to select from the programs recently used, or “All Programs” to select from all the programs installed.
3. Select the proper program by pressing **▲ ▼** keys and press the **Select** key.

A comment for the selected program is displayed by pressing **▶** key, and will disappear by pressing **◀** key.

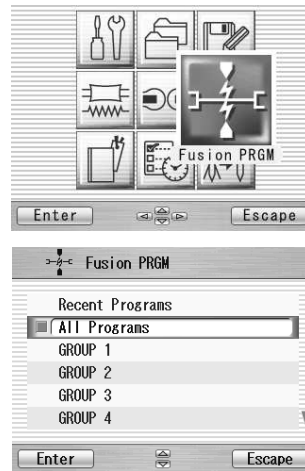

## Basic Operation

---

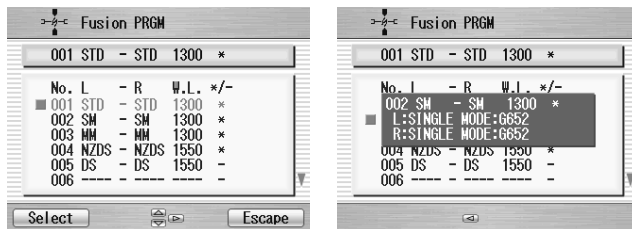

When the S153 Ver.2 is turned on, the last program used is selected automatically.

### Program list For Splice

Program No	Program name	Fiber type
001	STD-STD	For G652,G653,G655,and G657
002	SM-SM	For Single Mode Fiber
003	MM-MM	For Multi Mode Fiber
004	NZDS-NZDS	For Non Zero Dispersion Shift Fiber
005	DS-DS	For Dispersion Shift Fiber

### 6.2.2. Heat Program

1. Press the Menu key to display the menu screen.
2. Select the proper program by pressing ▲ ▼ keys and press the Select key.
3. Refer to the “Heater PRGM” display for details of the preinstalled programs.
4. Press the Escape key repeatedly until the Ready screen is displayed.

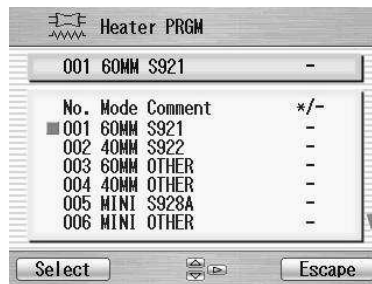

When the S153 Ver.2 is turned on, the last program used is selected automatically.



The curl removing program is installed in program No.010.

The curl-removing program can be selected from the heater program menu. Additionally, it can be selected by long pressing the heating key, when the heating status icon is blue.

It automatically returns to the heating program of the previous state, when all processes of curl-removing end once.

When doing curl-removing heating, set the fiber which isn't prepared in a heater. Please close the clamp in both sides and the cover like usual heating.

## Basic Operation

---

### Program list For Heater

Program No	Program name	Sleeve type
001	60MM S921	For Sleeve Length 60mm (S921)
002	40MM S922	For Sleeve Length 40mm (S922)
003	60MM OTHER	For Sleeve Length 60mm (For other 60mm sleeve)
004	40MM OTHER	For Sleeve Length 40mm (S922)
005	MIMI S928A	For Mini Sleeve (S928A)
006	MINI OTHER	For Mini Sleeve (For other mini sleeve)
007	60MM CONTINUOUS	For Sleeve Length 60mm
008	40MM CONTINUOUS	For Sleeve Length 40mm
009	blank	
010	CURL REMOVE	Removing fiber curl
011	SOC	For Sleeve Length 20mm (For Splice on connector)
012-016	blank	
017	40MM S922 POWER	For Sleeve Length 40mm (S922) with Pre heating
018	60MM S921 POWER	For Sleeve Length 60mm (S921) with Pre heating

### 6.2.3. Selecting the Operating Language

The S153 Ver.2 fusion splicer can be set to provide operating prompts in several languages. The default operating language is English.

1. From the Ready screen, press **Menu** key to access the Menu screen.
2. Select “Setting” and press **Enter** key.
3. Select “Parameter” sub-menu and press **Enter** key.
4. Select “Language” and press **Enter** key.
5. Pop-up window shows the current language. Press **▲ ▼** keys to scroll the languages and press **Set** key to change.
6. Press **Escape** key and the pop-up window will confirm the change. Select “Over write” to confirm the change, or “Cancel” to cancel the operation and press **Enter**.
7. Press the **Escape** key repeatedly until the Ready screen is displayed.



## 7. Fusion Splicing

### 7.1. Basic Splicing

---

#### 7.1.1. Arc Check

Because fibers melt or fuse at different temperatures, it is necessary to adjust the arc power to ensure optimum splicing results. Electrode wear can also affect the splicing results. Therefore, an Arc Check should be performed everyday prior to initial use of the machine, or when high splice losses are observed.

1. Open the windshield and load fibers. Ensure that the fibers are properly stripped, cleaned and cleaved. Refer to “Preparing the Fiber” for detail.
2. Close the windshield.
3. Select “Arc Check” in the Menu screen and press **Enter** key.
4. The S153 Ver.2 fusion splicer automatically feeds the fibers and discharges an arc.
  - During the arc discharge, the fiber feeding motors of the S153 Ver.2 fusion splicer remains idle, preventing the fiber ends from butting. As a result, the fiber ends melt back.



## Operating Instructions

---

- The arc check function inspects how far the fibers melt back and the centered position of the fiber is located. If the arc check results are good, the message “RESULT: OK” is displayed in the pop-up window. Press **OK** key to return to the Menu screen.
  - If the results of the arc check fails, “RESULT: NG Try again” is displayed. Press **Retry** and the machine will automatically adjust the arc power, and then return to the Menu screen.
5. When NG is shown, repeat the arc check to determine the new values until they are acceptable. It is necessary to remove the fibers and re-prepare them again with a new cleave before performing next arc check. If unsatisfactory results are obtained after four (4) arc check attempts, inspect the electrodes for wear or damage, and replace them if necessary.



- ◆ *A visual arc check can be made by viewing the arc on the monitor by pressing **⚡** key. Electrode discharge should produce a straight and steady arc. Swaying in the arc indicates that the electrodes require either cleaning or replacing.*
- ◆ *When the “Data Output” in the “Parameter” of “Setting” menu is set “Active” or “PC”, detailed arc*



## Operating Instructions

---

check data is shown in the result. Pressing **Optimize** key enables automatic adjustment for the arc power, while **Cancel** key does not adjust or complete the arc check.

- “RETREAT AAA(BBB-CCC)  
AAA: Melt back value  
BBB: Lowest allowable value  
CCC: Highest allowable value
- POWER DDD(+EEE)→FFF  
DDD: Recommended arc power  
EEE: Compensated value for environment changes  
FFF: Current arc power
- CENTER GGG ( $\pm$ HHH)→III  
GGG: Current arc center  
HHH: Allowable range of arc center  
III: Recommended arc center

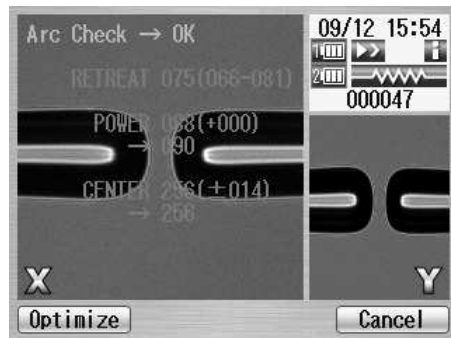

## 7.1.2. Preparing the Fiber

Splice loss is directly affected by the quality of the fiber preparation. For best results, ensure that the V-grooves are clean and that the fiber ends are properly cleaned and cleaved.

1. Slide a splice protection sleeve onto either the right or the left fiber.

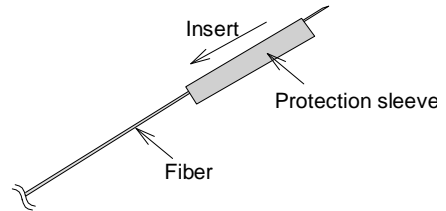

1. Strip approximately 30mm of fiber from holder. Refer to the manual of the stripper for details.
2. Wipe the bare fiber with a lint-free tissue soaked with denatured alcohol.

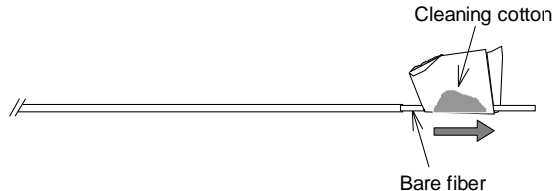

## Operating Instructions

---

3. Cleave the fiber so a proper length of bare fiber extends past the fiber coating (depending on the fiber holder type). Refer to the manual of the cleaver for the details.
- ◆ *Do not clean the bare fiber after it has been cleaved*
  - ◆ *Do not let the bare fiber tip come in contact with any surfaces.*
  - ◆ *Do not look into a fiber with the naked eye during operation. Wearing protection glasses is recommended.*

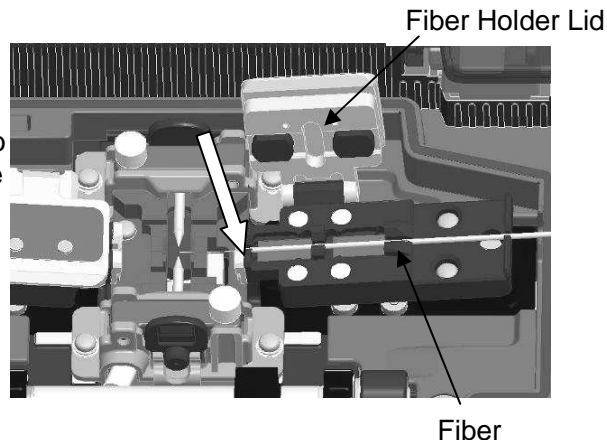

### 7.1.3. Loading the Fiber

1. Open the windshield.
2. Open the fiber holder lid and carefully place the cleaved fiber in the fiber holder as shown to the right. Be sure that nothing touches the bare fiber tip and place the coating end at the end stop inside the fiber holder (arrow mark).
3. Close the fiber holder lid, while carefully holding the fiber at the proper position.
4. Set the other side of the fiber.
5. Close the windshield, then READY screen is displayed.



- ◆ *Do not slide the tips of the fiber ends through the V-groove tracks.*
- ◆ *Make sure that the fiber tips are positioned between the center of the electrodes and the end of V-groove.*
- ◆ *The end plate only stops the end of 900 $\mu$ m coating. The 250 $\mu$ m coating is free.*
- ◆ *When performing a dissimilar fiber splice, the orientation of the fibers is of no concern. Either fiber can be placed on the left or right side of the S153 Ver.2.*
- ◆ *When setting loose tube fiber, set to clamp the fiber part by the inside clamp of the holder lid and to clamp the tube part by the outside clamp of the holder lid. When performing the tension test, enough screening power might not be applied for the loose tube fiber.*

### 7.1.4. Fusion Splicing

1. Ensure that the "READY" screen is displayed on the monitor.
2. Press  to initiate the fusion splicing cycle.
3. The S153 Ver.2 fusion splicer performs the following functions automatically. To pause the S153 Ver.2 fusion splicer during any of these functions, press . The message PAUSE will be displayed on the monitor. To restart the operation, press  again.
  - The right and left fiber ends appear on the LCD monitor. (High speed fiber feeding)
  - A cleaning arc is discharged to clean the fiber ends.
  - The fibers are set with a gap of about 20  $\mu$ m between the ends.

## Operating Instructions

---

- X screens are zoomed up.
- The fibers are inspected for axis offset and cleave condition.
- The cores of the fibers are aligned on the X and Y view screens.
- The electrodes discharge.
- The splice is inspected.
- The splice loss is estimated and displayed on the LCD monitor as shown in the picture.

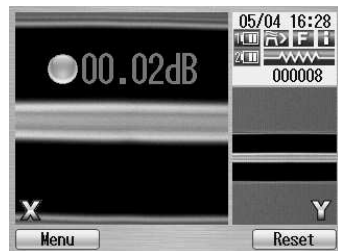

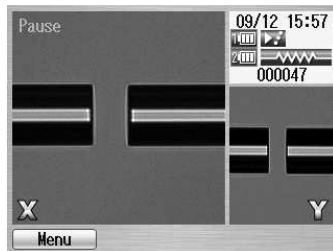

4. While in Pause status, pressing **Menu** key displays options available in the process. To resume the process, press  again.



## Operating Instructions

---

- Menu: Display the Menu Screen.
  - Zoom: Zoom in on the fiber image.
  - Capture: Capture the fiber image and store it with the splice data.
  - Field Change: Switch the fiber view between X and Y.
- ◆ *If an abnormality was detected in the process, the estimated loss is displayed with “>” instead of “=”, to indicate the error occurrence in the cycle. (Example: LOSS > 0.04dB)*
- ◆ *To discharge an additional arc, press ; splice inspection and loss estimation are re-performed.*
- ◆ *If the fibers fail the inspections for cleave criteria, the fusion cycle is paused and an appropriate error message is displayed as below. Open the windshield, remove the fibers after READY is displayed and retry the splice by repeating the entire procedure, starting from the fiber preparation process. To ignore the error and continue the cycle, press  again.*





The following operation mode is also available. Refer to 8.5.1 for the mode setting.

- The process stops at certain steps to ensure each step by operator.
- Initiate the splice automatically by closing the Windshield.

## 7.1.5. Splicing Defects

Defect	Possible Causes	Action
Bubbling	Wrong fiber type selected	Select the correct Fusion Program, and repeat fusion splicing.
	Faulty cleave	Repeat fiber preparation and fusion splicing.
	Dirty fiber end	Repeat fiber preparation and fusion splicing.
	Degradation of electrodes	Replace the electrodes.
Not spliced or Neck-down	Wrong Fusion Program selected	Select the correct Fusion Program, and repeat fusion splicing.
	Faulty cleave	Repeat fiber preparation and fusion splicing.
	Excessive arc current	Perform an arc check, and adjust arc power.
	Insufficient fiber feed	Adjust the fiber feed amount.
	Degradation of electrodes	Replace the electrodes.



## Operating Instructions

---

Thickening	Wrong Fusion Program selected	Select the correct Fusion Program, and repeat fusion splicing.
	Excessive fiber feed	Adjust the fiber feed amount.
	Degradation of electrodes	Replace electrodes.
	Excessive arc current	Perform an arc check, and adjust arc power.
Streak	Wrong Fusion Program selected	Select the correct Fusion Program, and repeat fusion splicing.
	Degradation of electrodes	Replace the electrodes.
	Weak arc	Perform an arc check and adjust arc power, or apply an additional arc.

### 7.1.6. Removing the Spliced Fiber

1. Raise both heater clamps before removing the fiber.
  2. Open the windshield. A tension test (200 g) is performed on the fibers.
  3. Buzzer beeps once when the tension test is completed.
  4. Remove the spliced fiber, pulling slightly so that the fiber is taut.
- ◆ *Handle the spliced fiber carefully. Do not twist the fiber.*



**CAUTION**

Do not attempt to load fibers while the S153 Ver.2 fusion splicer is resetting. Load the fibers only after the reset operation is complete and the READY screen is displayed.

### 7.1.7. Reinforcing the Fusion Splice

1. Slide the splice protection sleeve over the splice.
2. Place the spliced fiber in the heater – right-side first – to force the right heater clamp to close.
3. Ensure that the stainless steel rod in the sleeve faces down and the splice protection sleeve rests in following right position.

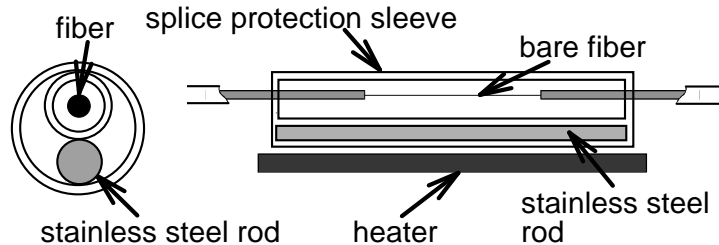

## Operating Instructions

---

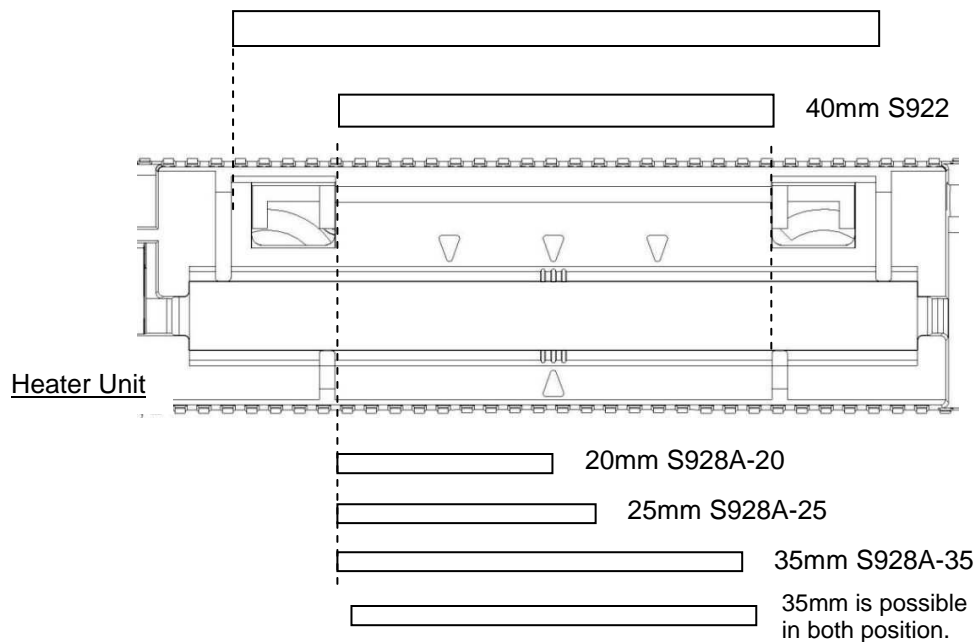



## Operating Instructions

---

4. Keeping the fiber taut with the left hand, lower the spliced fiber to force the left heater clamp to close.
5. Close heater cover.
6. When fiber is set and left clamping is shut, the HEAT LED turns on red and the heating starts automatically.

(When auto start function is invalid, press  key to activate the heater.)

The heating process is displayed in the LCD monitor with status icons as below.

	Blue: In ready mode. Red: In heating mode. Orange: In preliminary heating mode.
	In cooling mode.
	Error occurring.

When the heating and cooling operations are completed, a beep sound is heard.

- ◆ *To stop the heating operation (the HEAT LED is lit), press . The heating stops immediately.*
- ◆ *While the ambient temperature is lower than 10 °C, the heating time is automatically extended by 5 to 15 seconds.*

## Operating Instructions

---

7. Remove the fiber from the heater, and inspect the splice protection sleeve.

normal heating

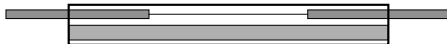

excessive heating

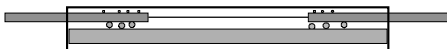

insufficient heating

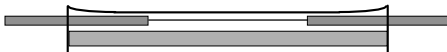

## WARNING

- STOP using the fusion splicer when problems are experienced with the protection sleeve heater. Turn off the power immediately, remove the battery and contact service center.

## 8. Programming Guide

### 8.1. Programming Functions and Menu



---

To start programming, user needs to access each function through Menu screen.



1. Press **Menu** (function) key to access the Menu screen. **Menu** key is available in the Ready screen and splice screens. When Menu is displayed in a pop-up screen, select the Menu and press **Enter** key.
2. Menu screen is displayed as shown (in picture to the right). Press **Escape** (function) key to return to the previous screen.





The following table is a list of functions available to the operator for programming and maintenance.

Menu Item	Features	Content
 <p>Arc Check</p>	<p>Perform arc check</p>	<p>Check arc intensity and automatically optimize to proper level. See “Arc Check, Getting Started”</p>
 <p>Tool</p>	<p>Perform a self machine check</p>	<p>Automatically diagnose condition of machine.</p>
	<p>Measure fiber</p>	<p>Measure and indicate fiber’s clad diameter, core diameter, core offset between fibers, cleaving angles and/or gap between fibers.</p>
	<p>Measure environment condition</p>	<p>Measure and indicate ambient temperature, pressure, as well as heater temperature.</p>
	<p>Manually splice fiber</p>	<p>Allows operator to manually control entire splicing cycle (using the keypad).</p>
	<p>Capture image</p>	<p>Store, record or erase fiber image</p>

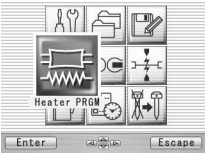
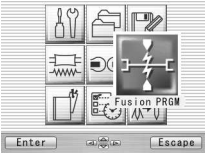

Menu Item	Features	Content
	Adjust shrinking Sleeve condition	Adjustment a shrinking condition of the sleeve
 <p data-bbox="240 519 336 550">History</p>	Manage Splice Data	Check previous splicing data, add comment, erase the data or transfer the data to PC.
	Obtain arc check data	Check arc data, add comment, erase the data or transfer the data to PC.
	Manager Fiber Image	Check fiber image, add comment, erase the image or transfer the image to PC.
 <p data-bbox="200 819 380 850">Program Edit</p>	Edit splicing programs	Change parameter values in the program, adjust inspection criteria for the splicing process or change program name.

Menu Item	Features	Content
	Edit heating programs	Change heat temperature, heat duration, and/or program name.
 <p data-bbox="193 557 382 583">Heater PRGM</p>	Show heat program list.	List all available heat programs for fiber reinforcement. User can select any from the list. See “Selecting a Fiber Program” in “Getting Started”.
 <p data-bbox="193 810 382 836">Fusion PRGM</p>	Show fusion program list	List all available fusion splicing programs. User can select any from the list. See “Changing Fiber Program” in “Getting Started”.

Menu Item	Features	Content
 <p data-bbox="224 428 355 459">Short Cut</p>	<p data-bbox="423 314 637 377">Set up short cut key</p>	<p data-bbox="685 294 1323 397">Save frequently used screen(s) with short cut key(s), so user can immediately access desired screen(s), when necessary.</p>
 <p data-bbox="238 683 334 714">Setting</p>	<p data-bbox="423 522 671 553">Set up parameters</p>	<p data-bbox="685 501 1323 573">Set up default language, Monitor direction, login name, sleep function, splicing start pattern, etc.</p>
	<p data-bbox="423 646 620 677">Set up counter</p>	<p data-bbox="685 605 1282 708">Get arc discharge times and/or splice counts. Set up recommended splice counts for the replacement/cleaning of electrodes.</p>
	<p data-bbox="423 718 671 781">Configure the data indicator</p>	<p data-bbox="685 718 1323 781">Turn measurement and/or estimation data during the splicing process on/off.</p>
	<p data-bbox="423 832 652 864">Adjust Date/Time</p>	<p data-bbox="685 801 1323 895">Adjust the date and time. Change the timer format indicating date and time.</p>

Menu Item	Features	Content
	Adjust LCD brightness	
	Check machine info	Get machine's manufacturer S/N, software version.
 <p data-bbox="200 605 375 636">Maintenance</p>	Replace/Clean electrodes	Step-by-step tutorial that illustrates how to replace/clean the electrodes, clean lens, or clean V-grooves & fiber clamps..
Clean lens	Clean V groove and fiber clamp.	

## 8.2. Program Edit

---

1. Select “PRGM Edit” in the Menu screen and press **Enter** key.
2. Select “Fusion” or “Heater” and press **Enter** key.  
 The following procedures and pictures are for Fusion program editing; however, the same procedure can be applied to the Heat programs.
3. Stored program list is displayed (as shown in picture to the right). Comment for highlighted program can be displayed by pressing **▶** key, and turned off by pressing **◀** key.
4. Select a program to be modified by pressing enter key and press **Menu** key to access to pop-up menu. Select a function and press **Enter** key.
  - Setting: Modifying main parameters.
  - Detail Setting: Modify detail parameters.
  - Default: Return the parameters to default value.
  - Copy: Copy the program and store with a new name.
  - Delete: Erase the program from the program list.
  - Edit: Editing comment of the program.

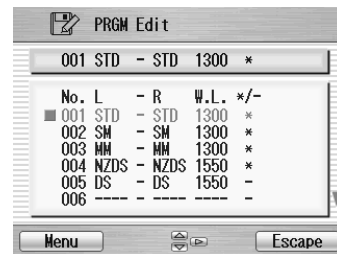

## 8.2.1. Setting

1. Select "Setting" and press **Enter** key in the pop-up menu.
2. Select "Splice" or "Inspect" tab with **◀ ▶** keys. Select parameters with **▲ ▼** keys and press **Enter** to edit.
3. Change the parameter with **◀ ▶** keys (increase/decrease appropriate digits) and/or **▲ ▼** keys (actual value) , and press **Set** key.
4. Press **Edit End**, the pop-up menu will show and ask following questions.
  - Over Write: Replace the parameter with the edited value.
  - Other Location: Store the program with new/changed parameter to a new location as a new program.
  - Cancel: Cancel the change and return to the previous screen.
5. Return to the parameter list. Select another parameter for editing or press **Escape** to complete the edit.



## 8.2.2. Detail Setting

1. Select "Detail Setting" and press **Enter** key in the pop-up menu.
2. A more detailed set of parameters is possible. The setting method is the same as "Setting".



Press ▲ ▼ keys : to move one by one item  
 Press **Enter** key : to move to next page

### 8.2.3. Default

Follow the procedures shown below to reset the modified program to the default parameters.

1. Select "Default" from Menu screen and press **Enter** key in the pop-up menu. The pop-up message window appears.
2. Press **Enter** key.
3. Select "Yes" and press **Enter** key to reset parameters to default parameters; or select "No" and press **Enter** key to cancel the operation.





### 8.2.4. Copy

Follow the procedures shown below to copy the selected program and paste it to a new location.

1. Select “Copy” and press **Enter** key in the pop-up menu.
2. Select a new destination for the program. The locations of the factory pre-installed programs can not be selected.
3. Press **Enter** key to paste the program.

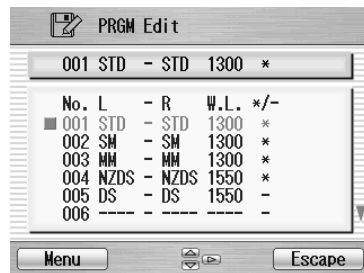

### 8.2.5. Delete

Follow the procedures shown below to delete the selected program.

1. Select “Delete” and press **Enter** key in the pop-up menu.
2. Pop-up message will be displayed on the screen asking “Delete Program?”. Press Enter Key to proceed the operation.
3. Select “Yes” and press **Enter** key to delete the program; or select “No” and press **Enter** key to cancel the operation. The factory pre-installed programs can not be deleted.



## 8.2.6. Edit Comment

Follow the procedure shown below to edit the comment of the selected program.

1. Select "Edit Comment" and press **Enter** key.
2. The screen shows current comment in the upper window and characters available for editing in the lower window.

3. Select a character in the lower window with **◀ ▶** and **▲ ▼**. press **Set** key to choose the character. The character with red color in the current comment is replaced with the selected character.

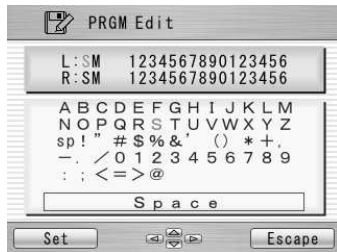

4. Press **Escape** key after new comment is edited.
5. The pop-up menu shows and asks following questions
  - Over Write: Replace the current comment with the edited one.
  - Cancel: Cancel the change and return to the previous screen.
6. Select "Over Write" and press Enter to save edited comment; Or select "Cancel" and press Enter to cancel the operation.



S153 Ver.2 splicer can store a maximum of 150 fusion programs.

- ◆ *Optimizing fusion parameters may call for other precise procedures, especially in the case of splicing various unlisted types of fibers. There are several hidden parameters which need to be taken into account when adjusting for optimum parameters. Contact FURUKAWA ELECTRIC CO.,LTD. or your local representative to get more information.*

## 8.2.7. Parameter Table

Parameter Table for Fusion Program

Parameter name	Min	Max	Description
For Splice			
1st Arc Start Power	0	200	Starting arc power in 1 <sup>st</sup> arc discharge.
1st Arc End Power	0	200	Ending arc power in 1 <sup>st</sup> arc discharge.
2nd Arc Start Power	0	200	Starting arc power in 2 <sup>nd</sup> arc discharge
2nd Arc End Power	0	200	Ending arc power in 2 <sup>nd</sup> arc discharge.
Arc Power Compensation	-127	128	Corrects the arc power based on the axis offset of the fibers
Cleaning Arc Power Offset	-127	128	Additional Arc Power for cleaning purposes
Cleaning Duration [ms]	0	32767	Arc duration for cleaning [msec]
Pre-fuse Duration [ms]	0	32767	Time between arc starting and fibers first butting [msec]
1st Arc Duration [ms]	0	32767	1 <sup>st</sup> arc time duration [msec].
2nd Arc Duration [ms]	0	32767	2 <sup>nd</sup> arc time duration [msec].
Z Pull Start Time [ms]	0	32767	Time to start to pull back the fiber [msec].
Z Push Distance [μm]	0	32767	Overlapping distance from fibers first butting position [μm].
Z Pull Distance [μm]	0	32767	Pulling back distance from the final overlapping position [μm].

## Programming Guide

Parameter name	Min	Max	Description
Z Push Type	0	2	Selecting the direction of splicing pushing.(0:left side fiber, 1:right side fiber, 2:both side fiber)
Start Time [ms]	0	32767	Starting time for pulse arc discharge in Main arc. (It could start from 1 <sup>st</sup> arc discharge or skip it and begin from 2 <sup>nd</sup> arc discharge, depending on first arc duration setting)
1st Arc On Time [ms] *1	0	32767	On time of pulse in 1 <sup>st</sup> arc discharge.
1st Arc Off Time [ms] *1	0	32767	Off time of pulse in 1 <sup>st</sup> arc discharge.
2nd Arc On Time [ms] *2	0	32767	On time of pulse in 2 <sup>nd</sup> arc discharge.
2nd Arc Off Time [ms] *2	0	32767	Off time of pulse in 2 <sup>nd</sup> arc discharge.
Re Arc Times [times]	0	255	Allowable numbers for the repeat arc in programmed additional arc mode. For example, "0" means no repeat arc is allowed.
Re Arc Duration [ms]	0	32767	Duration of additional arc [msec]
Re Arc Interval [ms]	0	32767	Interval between additional arcs and [msec]
Repeat Arc Power Offset	-127	128	Power of additional arc is Arc Power added by Repeat Arc Power Offset
Re Arc Power	0	255	Power of additional arc
Arc Mid Offset [μm]	-100	100	Spliced point offset from the arc center [μm]. See "explanation for arc mid offset".
Gap Offset [μm]	0	100	Offset value for pre-splice fiber position (um)

## Programming Guide

---

Parameter name	Min	Max	Description
Axis Offset Type	0	2	Attenuation splice method (0=No offset, 1=by splice loss value, 2=by fiber offset value)
Offset [ $\mu\text{m}$ ]	0.0	75.0	Function to allow clad offset splicing [ $\mu\text{m}$ ]
Gap [ $\mu\text{m}$ ]	0	184	Gap for the final position tuning(core or clad alignment) before the splicing [ $\mu\text{m}$ ].
For Inspect			
Cleave Angle [deg]	0	90.0	Maximum permissible angle of cleaved fiber end for splicing to continue [deg]
Loss Limit [dB]	0	15.0	Maximum loss allowed for machine not to give a splicing error [dB]
Wavelength [nm]	0	2000	Based on the wavelength [nm], each fusion program is optimized.
Mode Field Radius L $\mu\text{m}$	0	99.99	Mode field radius of left hand side fiber [ $\mu\text{m}$ ] (No meaning between L & R)
Mode Field Radius R $\mu\text{m}$	0	99.99	Mode field radius of right hand side fiber [ $\mu\text{m}$ ] (No meaning between L & R)

Time chart of fusion parameters

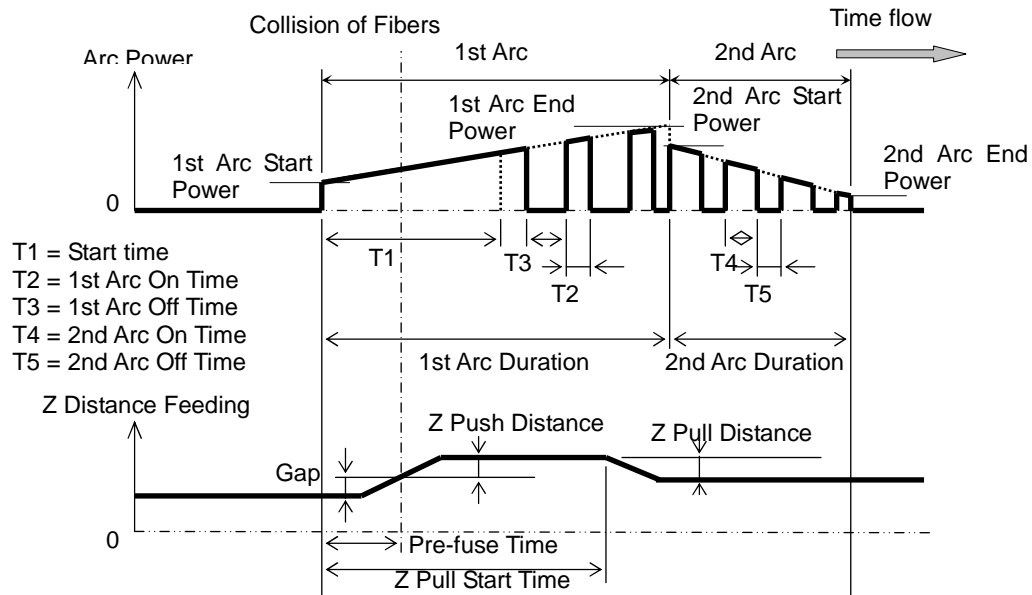

Arc power compensation table

	Cleaning Arc Power(1)	Fusion Arc Power(2)	Repeat Arc Power(3)
Common Arc Power	+	+	+
Arc Power-100	0	+	+
Arc Power Compensation	0	+: (eccentric core fiber) 0: (concentric core fiber)	0
Cleaning A-Power Offset	+	0	0
Repeat Arc Power Offset	0	0	+
Environment sensor Compensation	+	+	+

“+” marked terms are taken account to calculating each arc power



Parameter Table for Heater Program

Parameter name	Min	Max	Description
1 <sup>st</sup> Heat Temp IN [deg.C]	0	280	Temperature of INNER heater for the first half.
1 <sup>st</sup> Heat Temp OUT [deg.C]	0	280	Temperature of OUTER heater for the first half.
1 <sup>st</sup> Heat Time [sec]	0	300	Operation time of the first half.
2 <sup>nd</sup> Heat Temp IN [deg.C]	0	280	Temperature of INNER heater for The latter half.
2 <sup>nd</sup> Heat Temp OUT [deg.C]	0	300	Temperature of OUTER heater for The latter half.
2 <sup>nd</sup> Heat Time [sec]	0	300	Heating time after 1 <sup>st</sup> heating
Cool Temp [deg.C]	0	280	Temperature to arrive at end of cooling process.
Pre Heat Temp IN [deg.C]	0	280	Temperature of INNER heater for preliminary heating. Preliminary heating temperature before the first half.
Pre Heat Temp OUT [deg.C]	0	280	Temperature of OUTER heater for preliminary heating. Preliminary heating temperature before the first half.
Pre Heat Time [sec]	0	300	Operation time of preliminary heating after the end of cooling process or before the first half.

Auto Start	0	2	Setting for automatic start function. [0] : The non-operation. Manual start operation. [1]: The operation. When fiber set and left clamping is shut, the heating start automatically.*) [2]: The operation. Consecutive heating operation.
Compensation Auto Start	0	10	Expansion time of the automatic operation.

\* *Do not leave the protection sleeve in a heater after finish of shrinkage. There is the case that coating melts.*

## Time chart of heater parameters

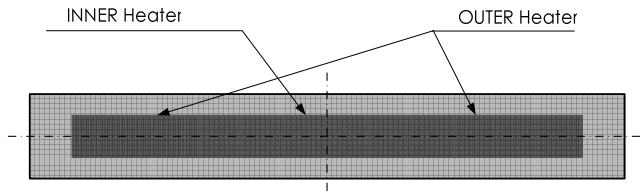
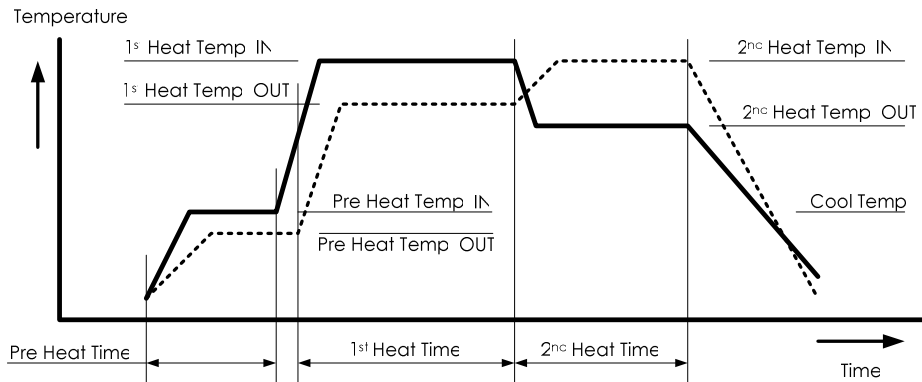

## 8.3. History

---

By selecting “History” in the Menu screen, the operator can access details of the splice data, arc check history and image archives; user can also add comments to each individual data. The data also can be transferred/ uploaded to PC or deleted from the memory.

1. In the Menu screen, select the “History” and press **Enter** key.
2. Select “Splice Data”, “Arc Check History” or “Image Data” and press **Enter** key to get the stored data.



### 8.3.1. Splice Data

1. If “Splice Data” is selected, a list of previous splice data is displayed on the screen (as shown in the picture below).
2. Select a targeted date and press Enter key to obtain the detail of the data as shown in the picture.



- As for the history with “\*”, the splice image is preserved automatically.

The data structure displayed are as follows;

Data Title	Description
CMNT	Comment of the data, which can be edited.
No.	No. 1 is the data for the last splice and the number increases for older splices.
Arc Count	Arc Count when splice was performed.
Date	Date and time for the splice performed.
PRGM	Name of Fusion Program.
W.L.	Wavelength
Arc Power	Value of Arc Power
AngL:	Cleave angle of the left fiber.
AngR:	Cleave angle of the right fiber.
AngT:	Relative cleave angle between left and right fibers.
Loss:	Estimated splice loss.
Note:	Error codes and additional arc memo if any. The data with error is highlighted. L: Estimated loss exceeds the target value S: Streak or bubble at the splice point or not spliced A: Cleave angle exceeds the criteria C: Cleave end face has excessive defects +: Additional arc is applied

3. Press **Enter** key and the pop-up shows available functions. Select desired function and press **Enter** to initiate the operation.
  - Comment Edit: Editing the Comment of the data.
  - PC-OUT: Transfer/Uploading the data to PC.
  - Delete: Deleting the data.

### **Comment Edit**

Refer to 8.2.6 for how to edit comment.

### **PC-OUT**

When you first connect the S153 Ver.2 to a PC, install driver software for S153 Ver.2 on your PC. Ask your representative or Furukawa Electric to obtain the driver software.

Follow the procedures shown below to upload the data to PC.

1. Turn on S153 Ver.2 and PC.
2. Connect S153 Ver.2 to PC with USB cable.
3. Open HYPER TERMINAL of Windows XP/2000 from start/All Programs/Accessory/Communication folder.
4. In "Connection Description" screen, name "S153 CONNECTION" in the box for the name of new connection and select Dial-up icon.
5. Select an appropriate communication port (COM2, for example) from "Connect To" screen.

6. Cancel the “Port Setting” window.
7. In Hyper terminal menu. Select Transfer then Capture Text. Hypertext will ask you name.
8. Name TEST for example. And remember location that TEST will be stored in. (Default would be C: / Program files/ Accessory/Hypertext.)  
Now hyper terminal is ready for receiving data.
9. Select “PC-OUT” in the pop-up menu of S153 Ver.2 and press **Enter** key.
10. Select “Current” for the desired/selected data or “All” for all the stored data and press **Enter** key. S153 Ver.2 will send data through hyper terminal to PC and you will see data in the window.
11. Select Stop in Capture text in Transfer menu when transfer is finished.
12. Open Excel and open a new file.
13. Go to folder in which TEST is stored and select file type All (\*. \*). Open the TEST file.
14. Text Import Wizard will open. Select Delimit (wizard 1/3), Tab and Comma (wizard 2/3), Column Data General (wizard 3/3).
15. Edit the data using Excel.

### **Delete**

1. Select “Delete” and press **Enter** key.
2. Select “Current” for deleting desired/selected data only, or “All Data” for all the stored data and press **Enter** key. The selected data is then deleted.



- ◆ *The splice data can be stored for the capacity up to 2000. Data older than 2,000 splices is automatically erased.*
- ◆ *When the splice is performed with an additional arc, the data shows final results after the additional arc.*

### 8.3.2. Arc Check History

1. The list of the previous arc check is shown on screen as it does for Splice Data.
2. Select a targeted time and press Enter key to obtain the detail of the data as shown in the picture.



The data obtained are as follows;

Data Title	Description
CMNT	Comment of the data, which can be edited.
No.	No. 1 is the data for the last arc check and the number is counted up for older arc checks.
Arc Count	Arc count when splice was performed.

Data Title	Description
Date	Date and time for the arc check performed.
PRGM	Name of Fusion Program.
W.L.	Wavelength
Arc Power	Value of Arc Power
Retreat	Value of how far the fibers melt back
Center	Value for centered position of the melt back

3. Press **Menu** key and the pop-up shows available functions. Select desired function and press **Enter** to initiate the operation.
- Comment Edit: Editing the Comment of the data.
  - PC-OUT: Uploading the data to PC.
  - Delete: Deleting the data.

Follow the same procedure as for Splice Data.

### 8.3.3. Image Capture

1. The list of the captured photos is displayed.
2. Select a photo and press **Enter** key to show the image and data as shown in the picture.

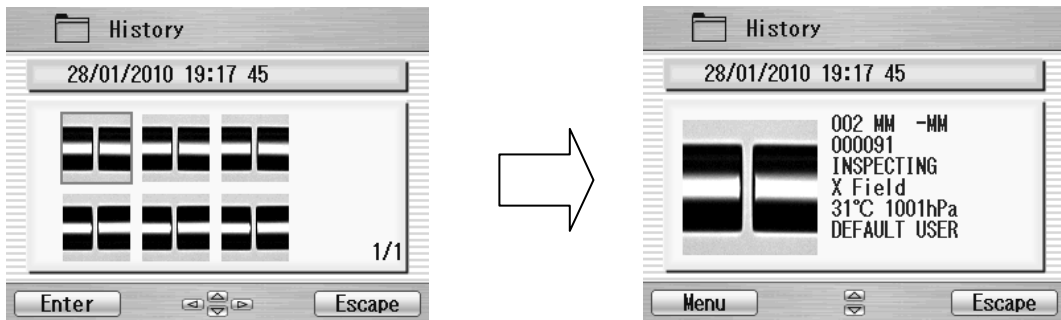

3. Press Menu key and the pop-up shows available functions. Select desired function and press Enter to initiate the operation.

- FULL Screen: Displaying the image in the full screen size.
- PC-OUT: Uploading the data to PC.
- Edit Comment: Editing the Comment of the data.
- Delete: Deleting the data.

Follow the same procedure for Splice Data.

The data displayed are as follows;

Sample	Description
002 MM - MM	Name of the Fusion Program
00091	Arc Count when splice was performed.
Gap Setting	Fibers gap when the image was captured
X Field	X or Y image
31 °C 1001hPa	Temperature and ambient pressure when splice was performed.
COMMENT	Comment

Follow the below procedure for PC-OUT.

1. Conect to PC and Splicer.
2. Open HYPER TERMINAL.
3. Select “PC-OUT” and press **Enter** key.
4. Select 「Receive File」 in 「Transfer」 of PC, then select 「Xmodem」, specified the save location ,and save data by “.bmp” format.
5. Open the save data on PC.

## 8.4. Tool

---

This menu provides with various kinds of utility functions.

1. Select "Tool" in the Menu screen and press Enter key.
2. Select a Sub-Menu in the table below and press Enter key.
3. Press the Escape key repeatedly to return to the Ready screen.

Sub-Menu	Function
Machine Check	Perform a self check of the machine condition.
Fiber Measuring	Performs an auto or manual inspection of the fiber with regards to clad and core offset, relative eccentricity, gap, fiber tilt and relative cleave angle.
Environment	View ambient temperature, pressure, as well as heater temperature.
Manual Splicing	Allows operator to manually control entire splicing cycle (using the keypad)..
Image Capture	Store and delete the fiber image.
Sleeve Shrink Adjust	Adjusting the shrinking condition of sleeve

## 8.4.1. Machine Check

1. A pop-up message prompts the user to remove the fiber from the machine. Follow the message and press OK key.
2. Select “Execute” in the pop-up screen and press Enter key to initiate the Machine Check. Or, select “cancel” to cancel the operation.
3. S153 Ver.2 automatically checks for dust in the camera and verify the motor movements (see sample screen to the right). Then, a pop-up screen prompts the user to set the fiber in place.
4. Set the fibers on both sides and press  to initiate the remaining check.
5. S153 Ver.2 automatically performs the remaining check and a pop-up message prompts the user to perform an arc check.
6. Press Enter key and select “Execute” or “Cancel” to perform the arc check. In the pop-up screen, press Enter key again.
7. After the machine check is complete, the pop-up screen shows “Status OK”. Press Escape key to finish the check.
8. If the machine fails Machine Check, the pop-up screen shows “Status NG. Call the Service Center”. Please call your representatives or Furukawa Electric for further assistance.
9. If arc check fails, pop-up screen shows “Status NG. Remove fibers, and retry Arc Check”. Perform an arc check to optimize the arc power.

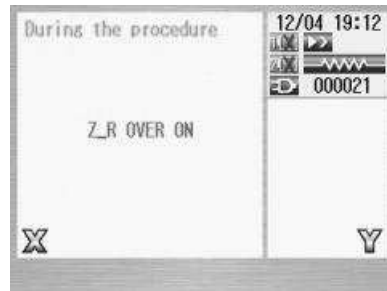

## 8.4.2. Fiber Measuring

The S153 Ver.2 performs an auto or manual inspection of the fiber (specifically, the clad and core offset, relative eccentricity, gap, fiber tilt and relative cleave angle).

1. Select “Fiber Measuring” in the “Tool” screen and a sub-menu is displayed.
  - Fiber feed & Measuring: Fiber is fed automatically at the measuring position, machine measures the fiber and display the result.
  - Fiber Measuring: Performs the measurement only. Fibers must be placed at an acceptable position manually. The results will be displayed after the measurement.
  - Motor Manual Move: Allows the measuring process to be done manually.
2. Load fiber on the machine.
3. Select “Fiber Feed & Measuring” and press **Enter** key. The machine automatically feeds and measures the fibers, and then displays the result.
4. Repeatedly press **Escape** key until the Ready screen is obtained.
5. The same content of results are displayed when the measuring is performed, using “Fiber Measuring” sub-menu. Be sure to place the fiber at an acceptable position before selecting the sub-menu.
6. Refer to 8.4.4 (Manual Splicing) for operating the “Motor Manual Move”.



## Measuring results

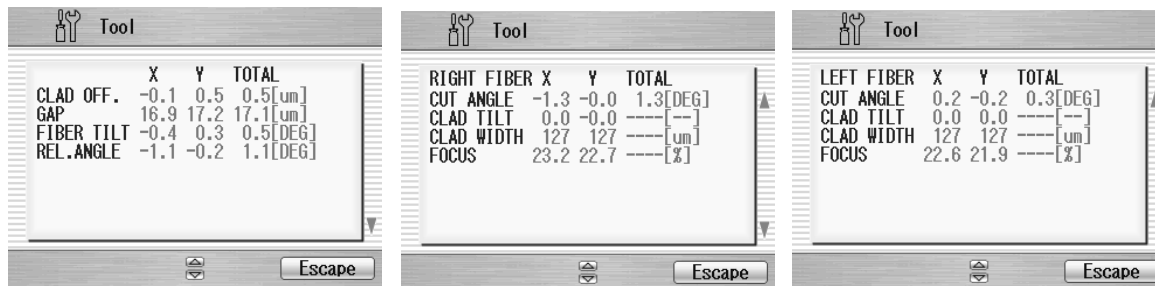

The results are shown in the following 3 pages. Press ▲▼ keys to switch screens.

### 1st Result Screen (Bilateral measurement)

PARAMETER	DESCRIPTION
CLAD OFF	Amount of CLAD OFFSET between the two fibers.
GAP	The GAP between the two fibers.
FIBER TILT	Angle at which fibers come into the screen.
REL.ANGLE	The RELATIVE cleave angle between the two fibers.

2<sup>nd</sup> and 3<sup>rd</sup> Result Screen (Right and Left fiber measurement)

PARAMETER	DESCRIPTION
CUT ANGLE	Cleave Angle of fiber in degrees
CLAD WIDTH	Measurement of CLAD width in micrometers
CLAD TILT	Angle at which fibers come into the screen.
FOCUS	Ratio of beam-width clad against

### 8.4.3. Environment

The S153 Ver.2 allows the user to view environmental conditions.

1. Select “Environment” in the Tool menu screen and press **Enter** key.
2. “Temperature” and Ambient “Pressure” are displayed. Press **°C<=>F** key to convert the temperature unit.
3. Press **Escape** key to return to the previous screen.

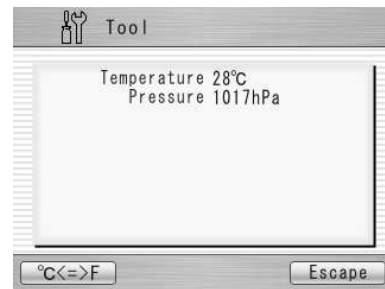

## 8.4.4. Manual Splicing

It allows the entire cycle of splicing to be operated manually using the keypad.

1. Select “Manual Splicing” in the Tool menu screen and press **Enter** key.
2. Select the preferred operating mode and press **Enter** key. Load fibers before selecting “Semi Auto”.
  - Semi Auto: Fibers are automatically fed and stopped at pre-splice position. Splice must be done by manual operation as described below.
  - Manual: All operations must be done manually following the procedures below.
3. The fibers are fed to the pre-splice position by pressing **Enter** key in the “Semi Auto” mode.
4. Select “Manual” and press Enter key to initiate the manual operation (see picture to the right). The left window shows the fiber image, and the right window displays the motion control commands.
5. The active motion control command is highlighted in red color. Move to other motions by pressing ▲▼ keys. Press ◀ ▶ keys to change the value or to activate the function. In “Arc” and “Reset”, press **Execute** key to activate the action.
6. Press **Escape** key to return to the previous screen.



**Variables which can be manipulated**

Command	Setting Menu	Description
Motor	Z_L	Activate left fiber feeding
	Z_R	Activate right fiber feeding
	ALN_X	Activate X-axis aligning
	ALN_Y	Activate Y-axis aligning
Move	◀	Drive the motor leftward
	▶	Drive the motor rightward
Speed	HIGH	Selecting high speed for motor movement
	LOW	Selecting low speed for motor movement
Dist.	FREE	Drive the motor step by step by pressing ◀ ▶ key.
	(Value) (μm)	Motor moves based on pre-set value. Selections from: Z: 5/50/500 ALN: 0.1/1.0/20.0
Arc	Clean	Selecting cleaning arc
	Arc	Selecting fusion splice arc
	Add	Selecting additional arc

Command	Setting Menu	Description
Reset	This	Reset the activated motor
	All	Reset all the motors
	Origin	
Field	X	Displaying X-axis image
	Y	Displaying Y-axis image
Zoom	IN	Zoom image
	OUT	Cancel zoom image
Pulse	(Value)	Showing current pulse position of the activated motor

### 8.4.5. Image Capture

The S153 Ver.2 allows the user to store and delete fiber images.

1. Select “Image Capture” and press Enter key.
2. Select “Capture” to capture and store image or “Delete data” to delete the image and press Enter key.

<Capture>

1. Select “X Field” or “Y Field” to store the image.|
2. Press Enter key (the image is then stored).
3. Press Escape key to return to the previous screen.

<Delete Data>

1. Select data with ▲▼ and ◀▶ keys and press “Delete” to erase it.|
2. Press Escape key to return to the previous screen.

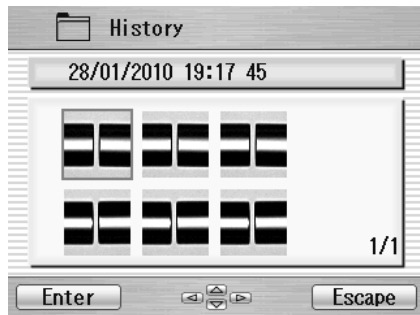
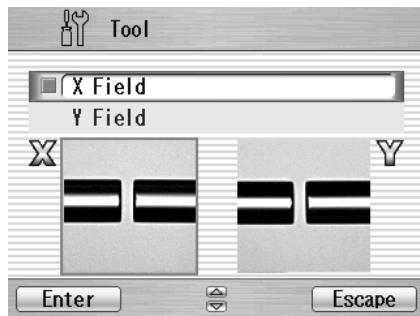

## 8.4.6. Adjusting shrinking condition of sleeve

Optimizing shrinking condition for the sleeve

1. Select "Sleeve Shrink Adjustment".
2. Select a pattern (A-E) that is similar to the current shrinking condition of the sleeve. And press **Enter** key.

Code	Condition of sleeve / Content
A	Not shrinking enough at sleeve end
B	Bubble in the center of sleeve
C	Fiber coating melts
D	Sleeve melts too much
E	Default to the factory setting

3. The heating condition is adjusted so that the shrinking condition for the sleeve become better.
4. If the adjustment is insufficient, repeat the above operation.



## 8.5. Setting

---

The following functions are available in Setting.

Sub-Menu	Setting item	Contents
Parameter	Language	Selecting default language
	Auto Start for Fusion	Selecting start mode Auto, Semi Auto or Cancel
	Auto Start for Heater	Selecting start mode Cancel, Auto or Repeat
	Data Output	Activating data output mode
	Stepping Action	Selecting splice operation mode
	Common Arc Power	Setting common arc power
	Buzzer Sound	Adjusting buzzer volume
	Buzzer Tone	Selecting buzzer tone
	Sleep Type	Selecting power save mode
	Sleep Time	Setting time for auto power off
	Calendar Format	Selecting calendar format
	Login Message	Activating login password



Sub-Menu	Setting item	Contents	
	Sensor	Activating environmental compensation	
	Display Image	Activating fiber image during arc discharging	
	Tension Test	Activating tension test	
	Direction of Monitor	Selecting monitor direction	
	Battery Mode	Selecting use for battery / 2 Batt. (parallel) or 1 Batt.(serial).	
	Illumination Lamp	Brightness control for LED lamp	
	Arc Counter	Displaying and editing arc count	
	Total Arc Counter	Displaying total arc count	
	Style Display	Select the display format of the screen X / Y	
	Charge Select	Select the battery to charge to prioritize	
	Charge Mode	Select the battery charge	
Counter	Arc	Counter Reset	Reset counter to zero
		Alarm On/Off	Activating alarm
		Alarm Count	Setting alarm count
	Cleaving	Counter Reset	Reset counter to zero

Sub-Menu	Setting item	Contents	
		Alarm	Activating alarm
		Alarm Count	Setting alarm count
	Stripping	Counter Reset	Reset counter to zero
		Alarm On/Off	Activating alarm
		Alarm Count	Setting alarm count
	Splicing	Counter Reset	Reset counter to zero
		Alarm On/Off	Activating alarm
		Activating alarm	Setting alarm count
	Total Arc	Setting alarm count	Activating alarm
		Alarm Count	Setting alarm count
Data	Before Splicing	Cleave Angle	Activating data display
		Clad Offset	Activating data display
	After Splicing	Cleave Angle	Activating data display
		Clad Offset	Activating data display
		Estimation Loss	Activating data display
Clock		Setting date and time	
LCD Adjustment		Adjustment LCD brightness and contrast	
About Machine		Information on machine	

1. Select “Setting” in the Menu screen and press Enter key.
2. Select Sub-Menu and press Enter key.
3. Select Setting item and press Enter key.
4. Follow the procedure below for setting each item.
5. Press Escape to return to the previous screen.

### 8.5.1. Parameter

1. Select a Setting item in the “Parameter“ list and press Enter key.
2. Pop-up window shows the current setting. Press ▲ ▼ keys to scroll the available settings and press Set key to change.
3. Press Escape key and a pop-up window will ask the operator to confirm the change. Select “Over write” to confirm the change, or “Cancel” to cancel the operation and press Enter.
4. Repeatedly press Escape key until the Ready screen is displayed.



- Language  
Select the display language

- Auto Start for Fusion

『Cancel ↔ Active ↔ Semi Auto』

『Cancel』	Auto Start function does not work.
『Active』	After setting fibers, even if you do not press the start key, splicing process is started by closing the windshield.
『Semi-Auto』	The fibers move to the center of the screen when the windshield is closed after the fibers are set and they stops temporarily. Then, it advances to the next process by pushing the start key and the splicing is done.

- Auto Start for Heater

『Auto ↔ Cancel』

『Auto』	When Fiber is set to the heater, heating start automatically.
『Cancel』	Auto Start function does not work. Press heating key.

### ● Data Output



Select display mode (display or hide) inspection data

『Cancel ⇔ Active ⇔ PC』

『Cancel』	Not display
『Active』	The data is displayed on the LCD screen.
『PC』	Output the data with the PC connected by USB cable.

### ● Stepping Action

『Type1 ⇔ Type2 ⇔ Cancel』

『Type 1』	Pause at before splice. (Press  to resume the process)
『Type 2』	Pauses at every process. (Press  to resume the process)
『Cancel』	It doesn't pause. If there is an error, it pause and an error message is displayed.

### ● Common Arc Power

Any value from 0 to 255. Select a digit with ◀ ▶ and press ▲ ▼ to increase/decrease the value. When “+” is selected, press ▲ key to jump to 255 or press ▼ key to jump to 0.

- Buzzer Sound

Setting Buzzer volume

『2 ⇔ 1 ⇔ 0』

『2 ⇔ 1 ⇔ 0』
Loud ⇔ Small ⇔ Mute

- Buzzer Tone

Selecting the buzzer tone.

『2 ⇔ 1 ⇔ 0』

- Sleep Type

Selecting the power save type

『LCD ⇔ ALL ⇔ OFF』

『LCD』	Only LCD turns off. The Power LED blinks at the power saving. It returns from the power saving state by the operation of opening the windshield or pressing any key.
『ALL』	Splicer turns off automatically without being operated for a while (=Sleep Time).
『OFF』	Cancel power save.

### ● Sleep Time

Time until shifting to the state of the power saving is set from 1 to 10 minutes.

『10 ⇔ 9 ⇔ 8 ⇔ . . . . . ⇔ 1』

### ● Calendar Format

Setting the display style of the date on the screen

『YYMMDD ⇔ MMDDYY ⇔ DDMMYY』

『YYMMDD』	Year Month Day (Eg. 2012 05 31)
『MMDDYY』	Month Day Year (Eg. 05 31 2012)
『DDMMYY』	Day Month Year (Eg. 31 05 2012)

### ● Login Message

『Cancel ⇔ Active』

When the log in message is set, the comment is displayed in the data of Splice history.



『Cancel』	Cancel
『Active』	Turning on, the setting screen of “Login Message” is displayed. The default setting is “DEFAULT USER”. When the comment is changed, Change the characters with the keys (◀ ▶, ▲ ▼, and <u>Execute</u> ) It returns to the ready screen when the <u>Return</u> key is pressed.

- Sensor

『Active ⇔ Cancel』

『Active』	Depending on the change in barometric pressure of the environment, the strength of the arc discharge is corrected automatically.
『Cancel』	Cancel

- Display Image

Activating fiber image during arc discharging

『Type 1 ⇔ Type 2』

- Tension Test

『Active ⇔ Cancel』

『Active』	Tension test starts by opening the windshield. Tension is 1.96N. Reset has been completed, unless the optical fiber is broken, the tension test is passed. Remove the spliced fiber carefully.
『Cancel』	Cancel tension test



### ● Direction of Monitor

Selecting direction of LCD screen

『Front ↔ Rear』

『Front』	The lower side of the LCD screen is the operating key.
『Rear』	The lower side of the LCD screen is the Heater. It is a direction that looks normal in the top and bottom of the screen when seeing from a rear side of the splicer.

### ● Battery Mode

Selecting battery use type

『2 Batt. ↔ 1 Batt.』

『2 Batt.』	Parallel use
『1 Batt.』	Serial use

### ● Illumination Lamp

Adjusting the brightness of the lamp. (The lamp that illuminates V-groove)

『15、14、13、· · · · OFF (turn off)』
Bright ↔ Dark OFF (turn off)

- Arc Counter

Displaying and editing arc count

Displaying the current count and can be adjusted to any count (up to 32767).

Select a digit with ◀ ▶ and press ▲ ▼ to increase/decrease the value.

When “+” is selected, press ▲ key to advance to 32767 or press ▼ key to advance to 0.

- Total arc Counter



Displaying total arc count

Only displays the current count and cannot be edited.

### ● Style Display

Selecting display layout for X/Y screens

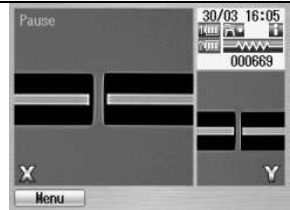
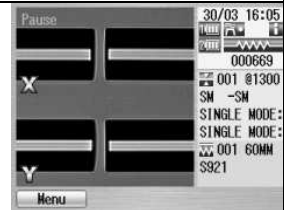
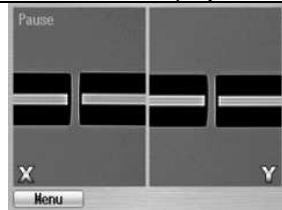
『0 ⇔ 1 ⇔ 2 ⇔ 3』

『0』	『1』	『2』	『3』
Side- by-Side	Up/Down	Side- by-Side without data display	Up/Down without data display
			

### ● Charge Select

The priority settings for the battery to be charged

『Low ⇔ High』

『Low』	Lower residual voltage battery is charged with priority.
『High』	Higher residual voltage battery is charged with priority.

- Charge Mode

Select the amount of battery level to be charged.

『100↔ 80[%]』

『100』	To charge up to 100% of battery capacity.
『80』	To charge up to 80% of battery capacity.

## 8.5.2. Counter

1. Select a Setting item in the “Counter“ list and press Enter key.
2. Pop-up window shows available functions. Press ▲ ▼ keys to select desired function and press **Enter** key.
3. Pop-up window shows available setting. Press ▲ ▼ keys to select desired setting and press **Enter** key.
4. Press Escape key and a pop-up window prompts the operator to confirm the change. Select “Over write” to confirm the change, or “Cancel” to cancel the operation and press Enter.
5. Repeatedly press Escape key until the Ready screen is displayed.



### Available settings for each Item

Setting Title	Functions		
	Counter Reset	Alarm On/Off	Alarm Count
<ul style="list-style-type: none"> <li>● Arc</li> <li>● Cleaving</li> <li>● Stripping</li> <li>● Splicing</li> </ul>	Do not Reset Reset	Off On	Displaying the current count can be adjusted to any count. Select a digit with ◀ ▶ and press ▲ ▼ to

● Total Arc	Not Available		increase/decrease the value. When “+ “ is selected, press ▲ key to advance to 32767 or press ▼ key to advance to 0.
-------------	---------------	--	---

### 8.5.3. Data

1. Select “Before Splicing” or “After Splicing” in the “Data” list and press Enter key.
2. Pop-up window shows available setting menus. Press ▲ ▼ keys to select desired setting and press Enter key.
3. Pop-up window shows “On/Off”. Press ▲ ▼ keys to select desired setting and press Set key.
4. Press Escape key and a pop-up window will prompt the operator to confirm the change. Select “Over write” to confirm the change, or “Cancel” to cancel the operation and press Enter.
5. Repeatedly press Escape key until the Ready screen is displayed.



***Data which can be displayed***

Process for Data Display	Data
Before Splice	<ul style="list-style-type: none"><li>● Cleave Angle</li><li>● Clad Offset</li></ul>
After Splice	<ul style="list-style-type: none"><li>● Cleave Angle</li><li>● Clad Offset</li><li>● Estimation Loss</li></ul>

- ◆ *“Data Output” in the “Parameter” must be “Active” to display the data.*

## 8.5.4. Clock

1. The setting screen is displayed (see picture to the right)..
2. Press ▲ ▼ keys to select setting item (Day/Month/Year/Hour/Minute) and press Adjust key
3. Select a digit with ◀ ▶ and press ▲ ▼ to increase/decrease the value, and press Set key.
4. Repeatedly press Escape key until the Ready screen is displayed.



## 8.5.5. About Machine

Various machine's info is displayed (see picture to the right).





## 8.6. Shortcut

---

The S153 Ver.2 allows the user to register a frequently used screen onto a “Shortcut”, and advance to that particular screen quickly.

### <Registering>

1. Select “Shortcut” in the Menu screen and keep pressing **Enter** key until the second beep sounds.
2. Select a shortcut menu in the screen. Press **▲▼** to scroll the menu item (highlighted in red color) and **◀▶** to change the page.
3. Press **Set** key to set the shortcut menu. Two short beeps will sound and the display returns to Menu screen.



### <Executing>

1. Press **Shortcut** key in the “Ready” screen or select “Shortcut” in the Menu screen and press **Enter** key. The screen changes to the registered one.

## 8.7. Maintenance

---

The S153 Ver.2 allows the user to obtain procedure and pictures for maintenance.

1. Select “Maintenance” in the Menu screen and press Enter key.
2. Select item from following list and press Enter key.
  - Replace/Clean electrodes
  - Cleaning for lens
  - Cleaning V groove and fiber clamp
  - Cleaning for main body
  - Agent Information
3. The maintenance procedures are displayed with text instructions and photographic examples. Press ◀ ▶ to switch the pages. Follow instruction to perform the maintenance.
4. Press Escape key to return to the previous screen.

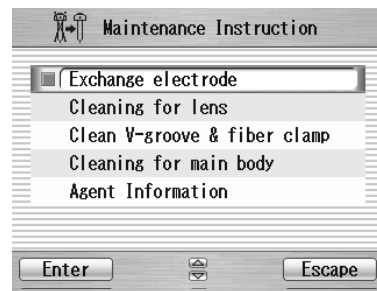

## 9. Maintenance and Handling Instructions

### 9.1. Error Messages

---

The following is a list of most commonly encountered error messages that can be observed. Refer to the following table for trouble-shooting.

Error Messages	Error Description	Cause of the error	Action
CUT ERROR (with side of the failed fiber)	Cleaving error is found in left fiber, right fiber, or both left and right fibers.	Exceeding the inspection criteria for cleave quality	Prepare the fiber again and retry.
		Incorrect parameters setting for cleave quality.	Check and correct the parameters.
SPLICE DEFECTS	See "Splicing Defects, Fusion Splicing".		
FEEDING ERROR (with name of the failed motor)	The motor does not stop after the time limit from the start.	Defect in the motor driving system.	Contact service center.

## Programming Guide

---

Error Messages	Error Description	Cause of the error	Action
OVER-RUN (with name of the failed motor)	The motor detected the overrun limit when running forward.	Fiber is not loaded or not in the proper position.	Load the fiber at the proper position.
		Inappropriate fiber program is selected.	Check and correct the program.
		Bad cleaving quality.	Prepare the fiber again and retry.
		Defect in the motor driving system.	Contact service center.
		V-groove is dirty	Clean the V-groove.
HEAT TIME OUT	The temperature does not reach the set value within the time limit from heating start up.	Incorrect parameter is set for heating.	Check and correct the parameters.
		Defect in the heating system.	Contact service center.

## Programming Guide

Error Messages	Error Description	Cause of the error	Action
Heater Error No.13	The temperature does not reach the set value within the time limit from heating start up. (*)	Incorrect parameter is set for heating.	Check and correct the heating parameters.
Heater Error No.17	The temperature does not reach the set value within the time limit from heating start up. (*)	Incorrect parameter is set for heating.	Check and correct the heating parameters.
		Voltage decrease	Recharge the battery. Use the AC adaptor
Heater Error No.18		Incorrect parameter is set for heating.	Check and correct the heating parameters.
Heater Error No.23		Incorrect parameter is set for heating.	Check and correct the heating parameters.
Heater Error No.27		Incorrect parameter is set for heating.	Check and correct the heating parameters.
		Voltage decrease	Recharge the battery. Use the AC adaptor
Heater Error No.28		Incorrect parameter is set for heating.	Check and correct the heating parameters.

## Programming Guide

---

Error Messages	Error Description	Cause of the error	Action
COOL TIME OUT	The temperature does not decrease to the set value within the time limit from cooling start.	Incorrect parameter is set for cooling.	Check and correct the parameters.
		Defect in the heating system.	Contact service center.
OVER TEMP.	The temperature exceeds the set value while heating.	Defect in the heating system.	Contact service center.
VISUAL ERROR	The image process cannot focus on the fiber, find the clad line.	Fiber is dirty.	Retry the splice from preparation. Make sure to clean the bare portion of the fiber.
		Defect in the image processing system.	Contact service center.
		Optics is dirty.	See Maintenance chapter.
OUT OF SPEC	The fiber is out of applicable range.	Cladding diameter is out of applicable range.	Can not splice with S153 Ver.2.

Error Messages	Error Description	Cause of the error	Action
LOW BATTERY	Battery has no power remaining.	Battery has no power remaining.	See “Recharging Battery”.

(\*)The Heater consumes a lot of electric power to shrink the protection sleeve fast. Therefore, the battery output voltage descends. In the battery that repeats 300-times electrical charge and discharges or more, the voltage descent under heating is large. When the voltage decent of the battery is large, the heating time is long, and the heater error 17 or the heater error 27 might be displayed. If the battery is charged full and the same error message is displayed, the battery might be weakening. Please use a new battery or use the AC adaptor.

## **9.2. Maintenance**

---

### **9.2.1. Arc Check**

Perform an arc check whenever high splice losses are observed (see 7.1.1).

### **9.2.2. Electrode Maintenance**

Inspect the electrodes for dirt, worn-out and damage before using the fusion splicer. Dust and other particles can be cleaned off by removing the electrodes from the splicing mechanism and polishing the surface of each electrode with the electrode sharpener. Over the course of normal operation, the electrodes can be cleaned & maintained for up to 5,000 splices.

Replace the electrodes if any of the following conditions exist:

- an electrode is bent
- an electrode end has become extremely rounded
- abnormal noise occurs during fusion splicing

When the Arc Counter number exceeds 1,000, the S153 Ver.2 automatically displays a message to prompt replacing the electrodes at power on. Turn off the switch and replace or clean the electrodes by using the electrode sharpener. The S153 Ver.2 asks if the electrodes are replaced after prompting the action. Select “Yes” if replaced and “No” if not. When “Yes” is selected, the Arc Counter is reset to 0 and the message will not appear at power on. When “No” is selected,



the prompting message will be displayed again when power is turned on.

- ◆ *Always replace or clean both electrodes, even if only one electrode is damaged.*
- ◆ *Be sure to turn off the Power switch before starting maintenance. Never touch the electrode while the Power is on.*
- ◆ *Longer arc duration used in dissimilar fiber splicing requires the electrodes to be cleaned and replaced more often. Frequent electrode maintenance is recommended for dissimilar fiber splicing programs.*

1. Loosen the screws of the Holding Plates, and raise the plates. The Electrode is raised together with the holding plate. Be careful not to drop the Electrodes into the machine.
2. Carefully pull and remove the Electrodes from the Holding Plates by grasping the Electrode Knob. Make sure nothing touches the Electrodes tips.
3. Clean or discard the Electrodes, as necessary.

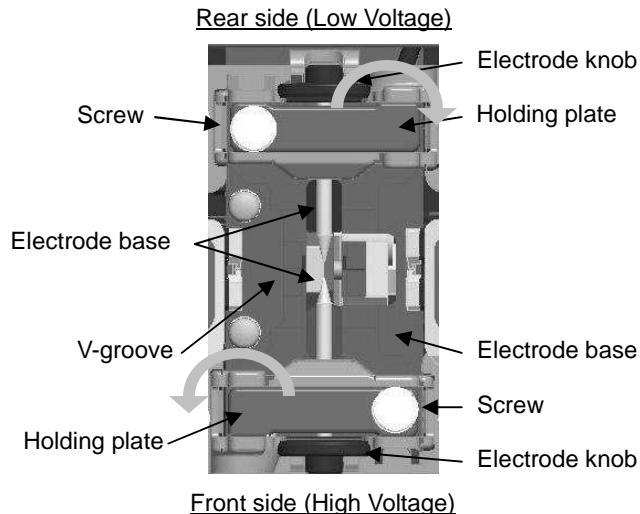

- ◆ How to clean the Electrodes by using the electrode sharpener.

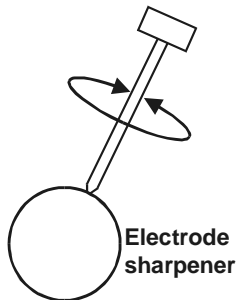

a) Firmly stick the tip of an electrode (approx. 0.5 – 1.0 mm) into the electrode sharpener and turn/twist the electrode 3-4 times.

Attention: Don't grasp the electrode knob (if possible, grasp a section of the electrode rod).

b) In an effort to clean the electrode tip, wipe it softly with BEMCOT dipping ethyl alcohol.

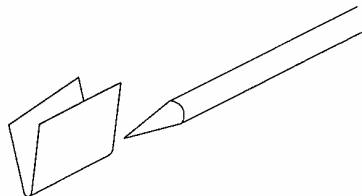

< Attention >

- You can use all faces of the electrode sharpener.
- Extreme treatment distorts the electrode tip and can possibly move the knob position.

4. When loading the electrodes into the splicer, push the electrode knob flush with the holding plate to ensure correct spacing.
5. Tighten the screws of the Holding Plates uniformly. **Do not overtighten the screws.**
6. Lower the windshield, and press ARC at least five (5) times to burn off any residue remaining on the electrodes.

### 9.2.3. Cleaning the objective lens

1. Remove the Electrodes.
2. Wipe the lens with a cotton swab soaked with denatured alcohol.
3. Dirty may prevent the splicer from performing a splice or may produce incorrect splice loss information.

### 9.2.4. Cleaning the V-grooves

- ◆ *Dirt on the V-grooves or fiber clamps will offset the alignment of the fibers or cause stress points on the glass, making the fiber weak.*
1. Prepare a piece of fiber and cleave it approximately 10mm from the end.
  2. Hold the fiber at a 45° angle.
  3. Run the cleaved end back and forth along each groove to scrape off any debris.
- ◆ *If the V-grooves are extremely contaminated, it may also be necessary to wipe the grooves with a cotton swab soaked with denatured alcohol.*

### 9.2.5. Cleaning the V-groove Fiber Clamps

1. Two Fiber Clamps are located in the windshield to help press the fiber into the V-grooves. Open the windshield.
2. Clean the top of the fiber clamps with a cotton swab soaked with denatured alcohol.

### 9.2.6. Cleaning the Tight-holder and Fiber-holder

Keep the grip parts of the holder clean. When they are dirty, fiber is sometimes slippery at the tension test. Wipe the rubber, lid part, and groove of Tight-holder or Fiber-holder with a lint-free tissue and a cotton bud, etc soaked with denatured alcohol. Clean the coating of fiber put on the holder, too.

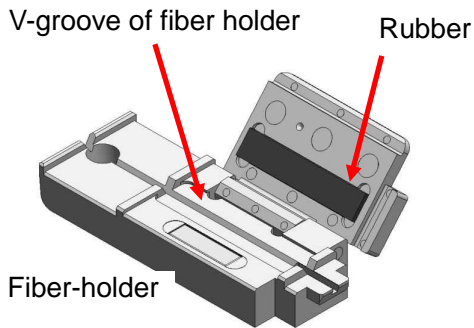
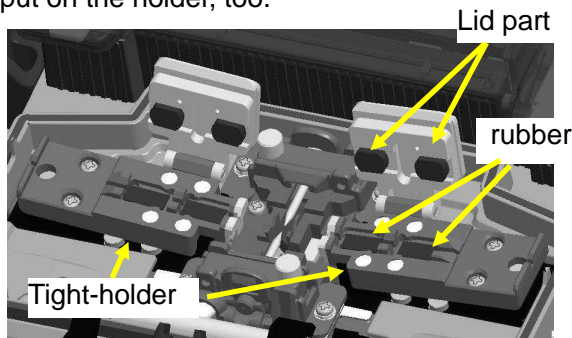

### 9.3. Back up battery

---

S153 Ver.2 has the backup battery other than the battery that operates the splicer. The backup battery is for the calendar and the memory preservation. The backup battery is rechargeable. When the S153 Ver.2 is turned on, the backup battery is charged.

If S153 is not used during about half a year, the backup battery becomes empty. When the backup battery empties, the preserved data is lost. When a warning mark  is displayed, turn on the power supply of S153 to charge with the backup battery before the backup battery empties.

### 9.4. Storing and Shipping

---

To maintain optimum operating reliability, do not store the S153 Ver.2 fusion splicer in locations where the temperature falls below  $-40^{\circ}\text{C}$  or rises above  $+60^{\circ}\text{C}$ . Also, avoid any environmental conditions that can result in internal condensation. Ensure that the cords are disconnected and the batteries are removed from machine's main body when storing the fusion splicer. Ensure that these temperatures and humidity requirements are also met whenever the S153 Ver.2 fusion splicer is shipped.

## **9.5. Claims and Repackaging**

---

Immediately inform Furukawa Electric Co., Ltd. or your local sales representative and, if necessary, the carrier, if the contents of the shipment are incomplete, or if the S153 Ver.2 fusion splicer or any of its components are damaged or defective, or if the fusion splicer fails during operation. In the event of carrier responsibility, Furukawa Electric Co., Ltd. will allow for the repair or replacement of the S153 Ver.2 fusion splicer or component while a claim against the carrier is being processed.

## **9.6. Return Shipments to Furukawa Electric Co.**

---

Furukawa Electric Co., Ltd. will only accept returns for which an approved Return Material Authorization (RMA) has been issued by Furukawa Electric Co., Ltd. customer service personnel. This number must be obtained prior to shipping any material back to Furukawa Electric Co., Ltd. The owner's name and address, the model number and full serial number of the S153 Ver.2 fusion splicer, the RMA number, and an itemized statement of claimed defects must be included with the return material. Never ship the S153 Ver.2 fusion splicer without or outside its carrying case.

- ◆ *If possible, return material in its original shipping container and packing material.*
1. Seal the shipping container securely and clearly mark FRAGILE on its surface.
  2. Always provide the model and serial number of the S153 Ver.2 fusion splicer and, if necessary, the RMA number on any accompanying documentation.





## 10. Option

### 10.1. Battery Charger: S958C

---

Charger for S943(B) battery

#### Power indicator

Green lighting : Turning ON  
Red & Green blinking : Power trouble

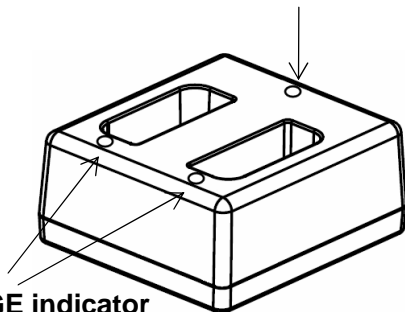

#### CHARGE indicator

Red lighting : During charge  
Green lighting: Charge complete  
Red & Green blinking : Trouble of battery

#### Input jack for S977A

#### Input jack for S977A

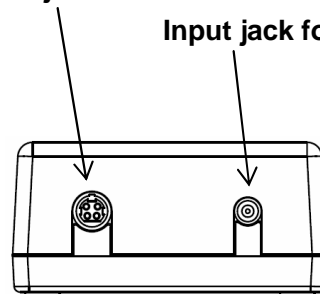

## Option

---

### ☆Charging

The number of the battery which S958C charger can charge at the same time depends on the AC adaptor.

Therefore, the S958C charger has two kinds of jacks that connect the AC adaptor.

Charge mode	AC adaptor	contents
Parallel	S976A	The two batteries are charged at the same times.
Serial	S977A	The battery is charged only one side. The battery of the remainder is charged when completing it.

When both S976A and S977A adaptors are connected, S958C charges batteries by S976A in the parallel charge mode.





**CAUTION**

**Never insert any other equipment except S943B (or S943) battery in S958C charger.**



**CAUTION**

**Do not use AC adaptors other than S976A (or S977A) for the S958C charger. When using AC adapter, do not use any voltage other than indicated. Doing so may result in fire, electric shock, or injury.**

	For charging the Battery, insert the Battery pack squarely into the slot of the charger. If the battery pack sits in the charger at an angle, the battery may not charge and charging errors may occur. In such a case, remove the battery pack, and replace into the charger taking care to seat it correctly.
	The charging errors may occur for the battery not charged with for a long time. In such a case, remove AC adaptor from out let once, and insert it again. And strat charging.
	It is necessary to attach a ferrite core to the line-out, when using the S977A AC Adapter.

## 10.2. Cooling Tray:CTX-01

---

Tray to cool sleeve after heating  
Set it in the back of the main body.

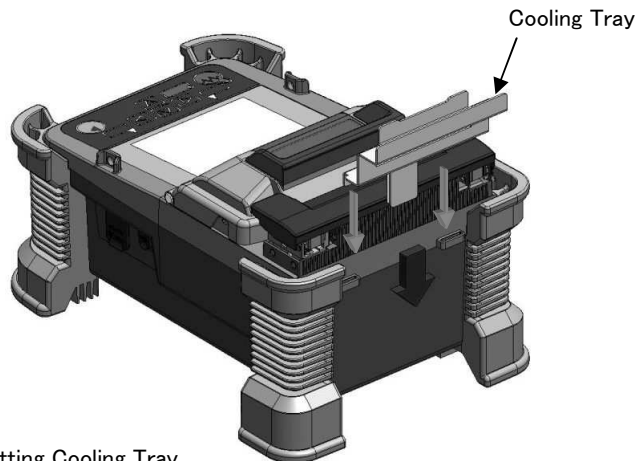

Setting Cooling Tray

### 10.3. Working Belt: WBT-01

---

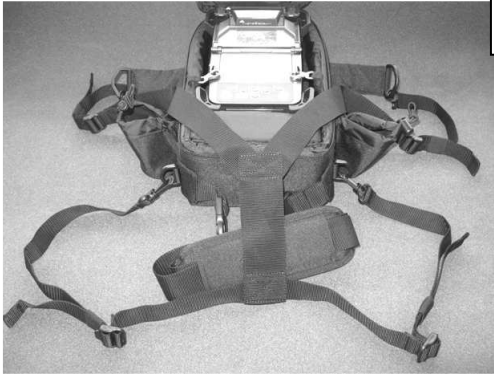

Adjust the length of the belt according to the body.



Connect each belt on each hook, put the fusion splicer, and fix with metal fittings.



## 10.4. Cleaning Brush:VGC-01

---

It is used to remove the garbage that adheres to V-groove and the fiber clamp.

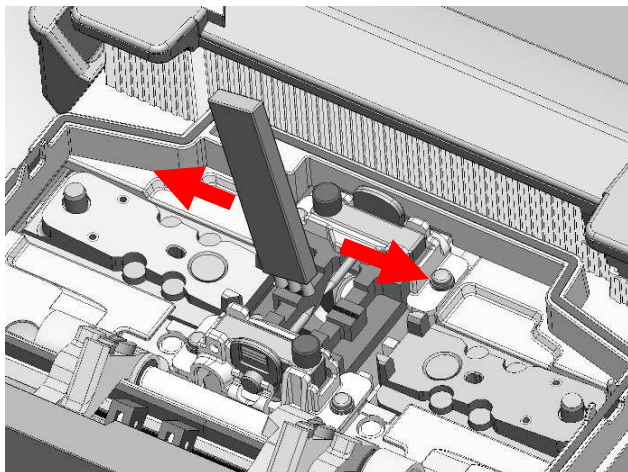

## 10.5. Hard carrying case:HCC-01

---

The lid of the hard carrying case can be remove.

How to remove is as follows.

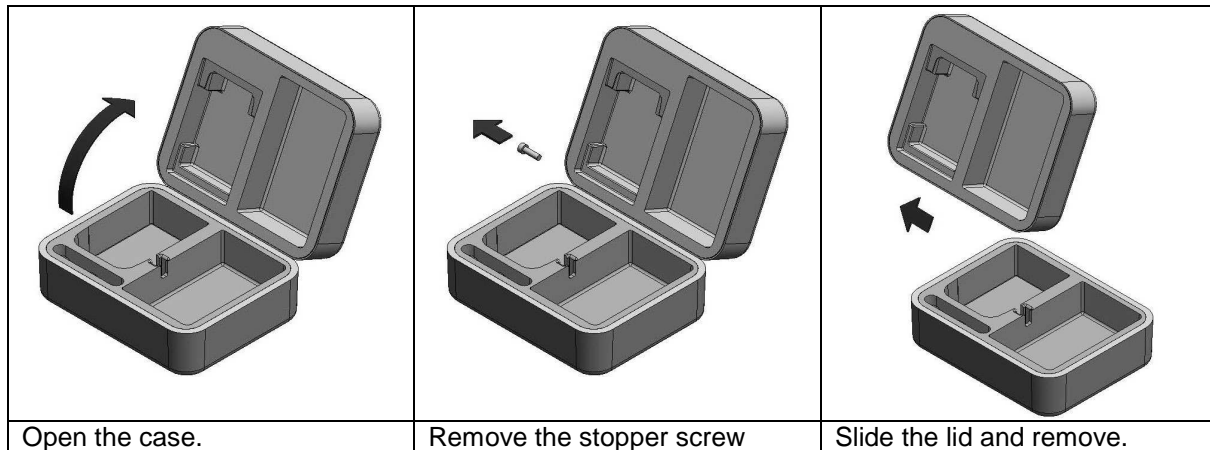

## 10.6. Tripod adaptor: TPA-01

---

Fix Tripod adaptor to the rear surface of the Bottom case with 4 screws.

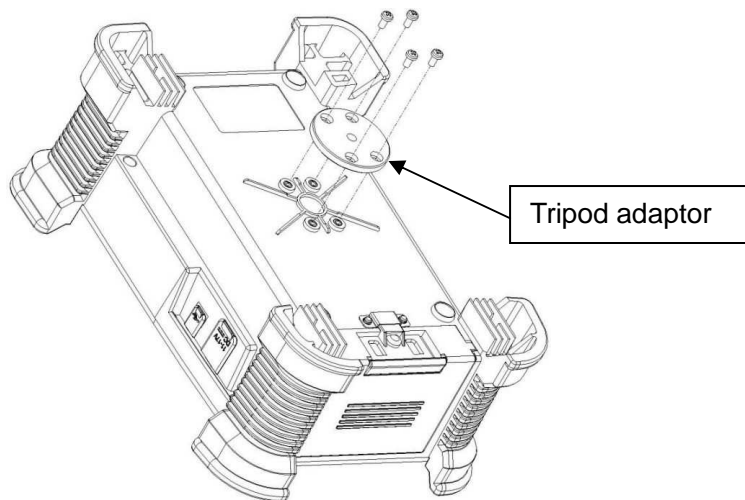



## 11. Recycling and Disposal

When you dispose S153 Ver.2 fusion splicer or its standard components, follow your local disposal regulations, or contact Furukawa Electric Co., LTD or your local representative.

To recycle, disassemble it first and sort each part by material and follow your local recycling regulations.



Especially for European Union, in accordance with the European Parliament Directive 2002/96/EC, electrical parts and materials that can be re-used and/or recycled have been identified in order that the use of new resources and the amount of waste can be minimized.

## Recycling and Disposal

---

S153 Ver.2 has a backup battery for backup memory and calendar.  
How to take off a battery is indicated in the following.

### Removing the built-in battery

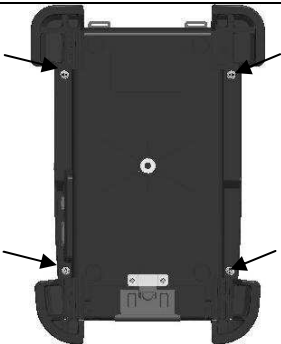
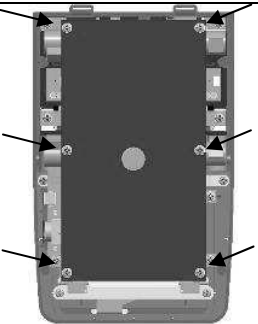
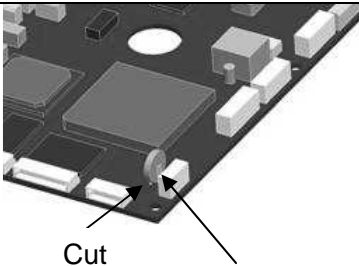
		 <p>Cut</p>
<p>1. Remove the 4 screws, and remove the bottom case.</p>	<p>2. Remove all wiring connected to the electric board. And remove 6 screws which fix the board.</p>	<p>3. There is the built-in battery in the back of the board. Please cut fittings off and tear the battery away.</p>

***For sales and service information,  
contact FURUKAWA ELECTRIC CO.,LTD.  
or your local representative.***

---



Sales Department:

Fiber Optics & Applications Global Sales & Marketing

Telecommunications Company Furukawa Electric Co., Ltd.

2-3, Marunouchi 2Chome, Chiyoda-ku, Tokyo 100-8322 JAPAN

TEL : +81-3-3286-3340 FAX : +81-3-3286-3978

Service Department:

CS2 Group

Access Network Department FITEL Products Division

Telecommunications Company Furukawa Electric Co., Ltd.

6 YAWATA-KAIGANDORI , Ichihara, Chiba, 290-8555 Japan

TEL : +81-436-42-1671 FAX : +81-436-42-1786

---