



S218R-200 Thermal Stripper Operating Instructions

- Please read entire manual prior to usage.
- Please keep this manual with the S218R-200.

Issue 03

November. 2019

FURUKAWA ELECTRIC CO., LTD.

Contents

Contents	1
1 Safety Instructions.....	2
2 Components.....	5
2.1 Standard Components.....	5
2.2 Optional Components.....	5
3 Specifications.....	5
4 Unit Description.....	6
5 Preparation	7
5.1 Battery setting	7
5.2 Charging the Battery.....	8
6 Operating Instruction.....	9
7 Adjusting temperature	10
8 Setting power save mode.....	10
9 Recharging Battery	10
10 Confirming Battery Remaining.....	10
11 Maintenance	10
12 Replacing the blade	11
12.1 Replacing the lower blade	11
12.2 Replacing the upper blade.....	11
12.3 Upper blade adjustment.....	12
13 Others	12
13.1 Mounting the Stand (Optional parts) for the unit	12
13.2 Storage for the S944 Battery Pack	12
14 Holding period for spare parts	13
15 Contacts.....	13

1 Safety Instructions

This manual contains the complete operating and maintenance instructions for S218R-200 Thermal Stripper. Please review this manual carefully before operating the S218R-200 Thermal Stripper.

The following safety instructions must be observed whenever this product is operated, serviced or repaired. Failure to comply with any of these instructions or with any precaution or warning contained in this manual is in direct violation of the standards of the design, the manufacture and the intended use of the instrument. FURUKAWA ELECTRIC CO., LTD. assumes no liability for the customer's failure to comply with these requirements.

Safety Instructions

	WARNING	Failure to comply with any of the instructions, which are indicated by this symbol, may cause serious injury or death.
---	----------------	--

	CAUTION	Failure to comply with any of the instructions, which are indicated by this symbol, may cause serious injury or damage to the AC/DC Power Supply and other materials.
---	----------------	---

Please contact FURUKAWA ELECTRIC CO., LTD. with any questions relating to the description of this manual.

In no case will FURUKAWA ELECTRIC CO., LTD. be liable to the buyer, for any consequential or indirect damage which is caused by product failure, malfunction, or any other problem.

	WARNING
<ul style="list-style-type: none"> • Avoid soaking the AC/DC Power Supply, Battery or Battery recharger with water. Doing so may cause fire, electrical shock or malfunction. 	
<ul style="list-style-type: none"> • Do not use inappropriate input voltage. Doing so may cause fire, electrical shock or malfunction. 	
<ul style="list-style-type: none"> • Do not use any AC/DC Power Supply other than the attached one. Do not use the attached AC/DC Power Supply as a power supply other than for the S218R-200. Doing so may cause fire or malfunction. 	
<ul style="list-style-type: none"> • Avoid direct skin contact with the heating portion. This may cause burn or injury. 	
<ul style="list-style-type: none"> • If smoke, abnormal sounds, extra high temperature or strange smells are observed, power off and disconnect the S218R-200 from the power source and contact FURUKAWA ELECTRIC CO., LTD. or your local representative. Continuing to operate under these conditions may cause fire, electrical shock or malfunction. 	
<ul style="list-style-type: none"> • Do not use a damaged power cord with the inner cable is exposed or is severed. Doing so may cause fire or electrical shock. 	
<ul style="list-style-type: none"> • If water spilled into the S218R-200, power off and disconnect the S218R-200 from AC outlet. Continuing to operate under these conditions may cause fire or electrical shock. 	
<ul style="list-style-type: none"> • If the S218R-200 is dropped and damaged, disconnect the power source. Continuing to operate under these conditions may cause fire or electrical shock. 	
<ul style="list-style-type: none"> • Do not operate the S218R-200 at temperatures less than 0°C or above 40°C. Do not expose to high temperatures. Doing so may cause fire, electrical shock or malfunction. 	
<ul style="list-style-type: none"> • Do not short-circuit the DC plug. Doing so may cause fire or electrical shock or malfunction. 	

The S944 Battery is made of Li-ion battery cells. Refer to following safety instructions on handling and operating the Battery safety.



WARNING

- Do not dispose the Battery in fire, or leave the Battery near a high-temperature object. Doing so may cause fire or explosion.
- Do not short-circuit the recharging connector or the output terminal for splicer. Doing so may cause fire by generation of heat.
- Charge the S944 Battery by the S218R/S218R-Plus/S218R-200. If charging by other equipment that is not suitable for charging S944, it may cause fire.
- Avoid soaking the Battery with water. Doing so may cause fire or electrical shock.
- Do not disassemble the Battery. Avoid damage by dropping or heavy shock. Doing so may cause fire or electrical shock. If inner cells rupture and electrolytic solution leaks outside, it may cause inflammation to your skin or eyes.
- Disposal of used Battery must be carried out according to disposal established by Law. For instructions, contact Furukawa electric Co., Ltd. or your local representative.



CAUTION

- Do not disassemble the S218R-200. The S218R-200 contains no user serviceable parts. Warranty on this product will be invalidated if any part of the S218R-200 is disassembled.
- Do not use in a humid, dirty or vibration site. Doing so may cause fire, electrical shock or malfunction.
- Do not place the S218R-200 on an unstable or inclined surface. The S218R-200 may fall and cause injury.
- Disconnect all cords when using DC cord and moving the S218R-200. Doing so may damage the cords which may cause fire or electrical shock.
- Do not place the S218R-200 around any heating instrument. Doing so may damage the cords which may cause fire or electrical shock.
- Do not connect or disconnect cord with wet hands. Doing so may cause fire or electrical shock.
- Do not pull the cord to disconnect. Doing so may damage the cord which may cause fire or electrical shock. Hold the plug portion and disconnect the cord.
- Do not put heavy items on the cords. Doing so may damage the cords which may cause fire or electrical shock.
- Use only the cord attached to the S218R-200. Connecting inappropriate cords or extending the cords may cause them to heat up abnormally and may cause fire.
- Do not modify the cords and do not over-bend, over-twist or over-stretch the cords. Doing so may cause fire or electrical shock.
- Ensure that the cords are disconnected, when storing the S218R-200.

Notes

This symbol mark is for EU countries only.

This symbol mark is according to the directive 2006/66/EC Article 20 Information for end-users and Annex II.

This symbol means that batteries and accumulators, at their end-of-life, should be disposed of separately from your household waste.

If a chemical symbol is printed beneath the symbol shown above, this chemical symbol means that the



battery or accumulator contains a heavy metal at a certain concentration. This will be indicated as follows:

Hg: mercury (0.0005%), Cd: cadmium (0.002%), Pb: lead (0.004%)

In the European Union there are separate collection systems for used batteries and accumulators.

Please, dispose of batteries and accumulators correctly at your local community waste collection/recycling centre.

Please, help us to conserve the environment we live in!

2 Components

2.1 Standard Components

Name	Code	Quantity	Remarks
Main Body	S218R-200	1	
Battery Pack	S944	1	Li-Ion Rechargeable Battery
AC adaptor	S952	1	AC→DC Converter
Allen key set	S218X-07	1	Tools used for replacing blade
Phillips-head screwdriver	S218X-20	1	Tools used for removing the Battery Pack
Case	S218X-04	1	Protection Case
Strap		1	
Cleaning brush		1	
Operating Manual	FTS-B580	1	

2.2 Optional Components

Name	Code	Quantity	Remarks
Blade for S218R-200	S218X-55	1(set)	
Battery Pack	S944	1	Li-Ion Battery
AC adaptor	S952	1	AC→DC Converter
Stand	S218X-23	1	

3 Specifications

Description	Minimum	Typical	Maximum	units
Fiber cladding diameter		125		μm
Rollable ribbon thickness	200		250	μm
Electrical				
Input terminals from AC supply	85		264	VAC
Power consumption			10	Watt
Dimension (W x D x H)				
Main body (S218R-200)		48 x 125 x 41		mm
S944 Battery Pack		39.5 x 55.8 x 20.9		mm
S952 AC adaptor		62 x 99 x 26		mm
Weight				
Main body (S218R-200)		180		g
S944 Battery Pack		80		g
S952 AC adaptor		270		g
Environmental				
Operating temperature	0		40	°C
Storage temperature	-40		60	°C
Humidity (Non condensing)			90	%RH

4 Unit Description

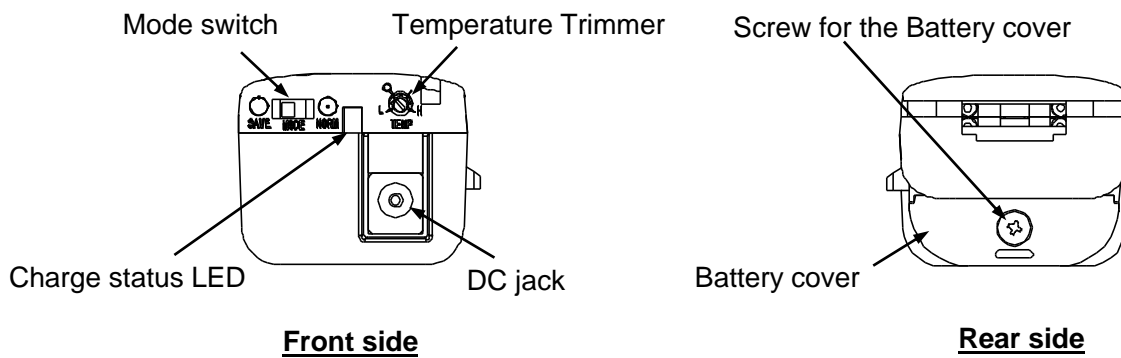
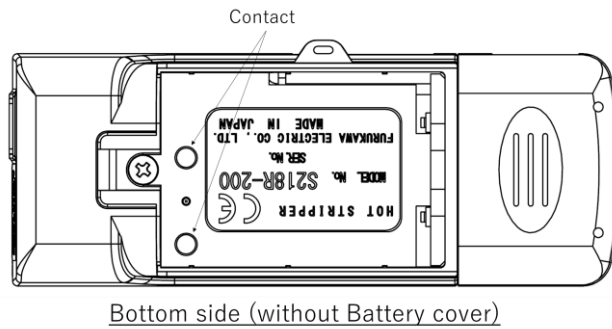
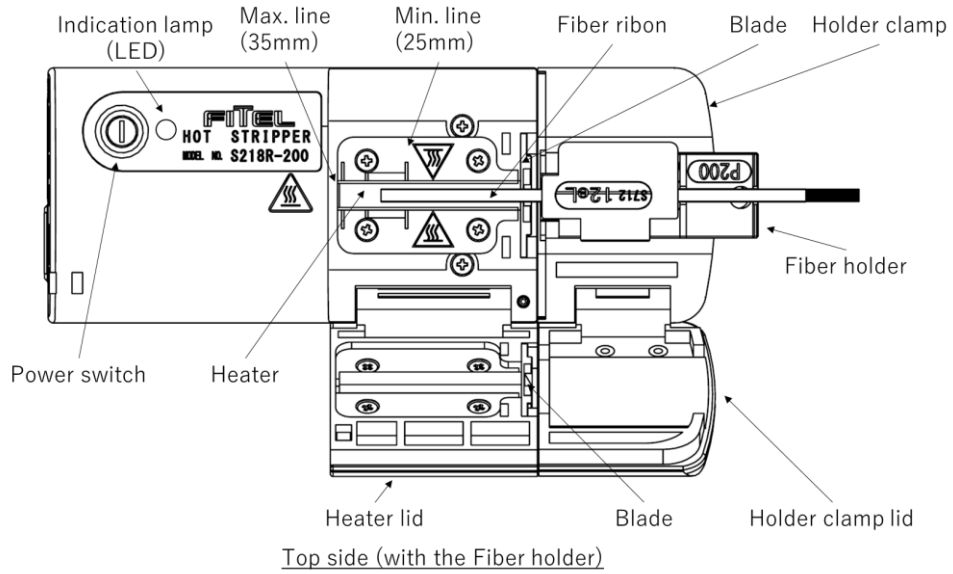

Polarity of DC jack

5 Preparation

5.1 Battery setting

Mount the S944 Battery Pack into the S218R-200 before using it.

- 1) Loosen the screw of the Battery cover by using an attached Phillips-head screwdriver.
- 2) Remove the Battery cover by pushing it to the direction as shown at right.

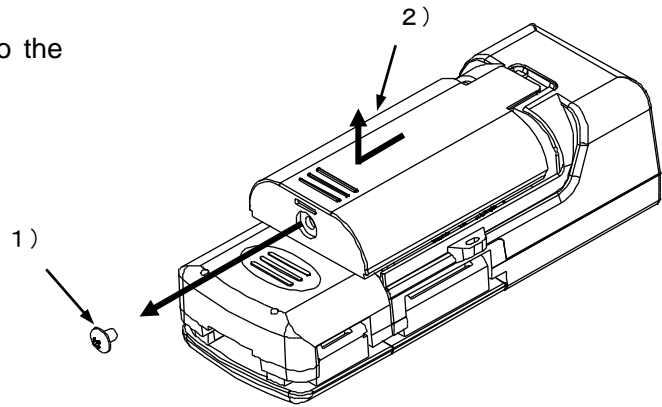

Remove the Battery cover

- 3) Set the Battery Pack in the Main body to fit both contacts.

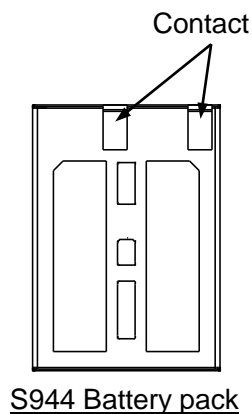

S944 Battery pack

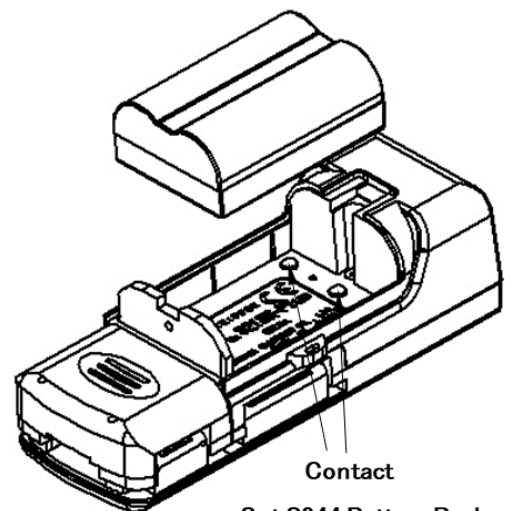

Set S944 Battery Pack

- 4) Put the Battery cover back to the unit, then tighten the screw.

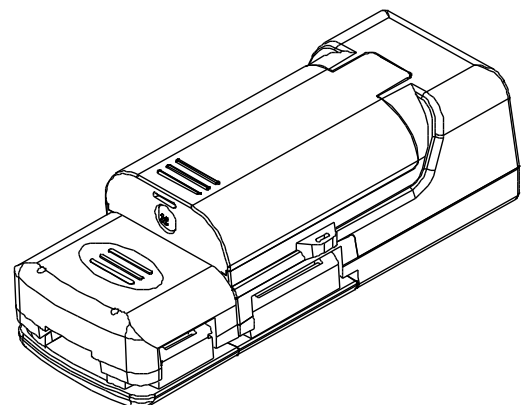

Screw the Battery Cover

5.2 Charging the Battery

- 1) Let S944 battery Pack be remained in S218R-200 Thermal Stripper.
 - 2) Connect S952 AC adaptor to AC power outlet (85-264V, 50/60Hz) using AC power cord.
 - 3) Connect S218R-200 Main body to S952 AC adaptor using DC plug cable.
 - 4) The orange charge LED will be illuminated and the battery will start to be charged.
- It will take approximately 150 minutes to fully charge the Battery. When the Battery is fully charged, the Charge status LED will turn off automatically.
 - S944 battery can be charged while the unit is being used, however, in such case, charging rate or speed is tenth of the rate when the unit power is off.
 - If charging errors occur, the orange Charge status LED will be blinking.

	Warning	If errors occur during charging process, please swiftly remove the S944 Battery Pack from Main body, then contact your local representative for assistant. It is dangerous to continuously operate the unit under these conditions, which may cause fire or electrical shock.
--	----------------	--

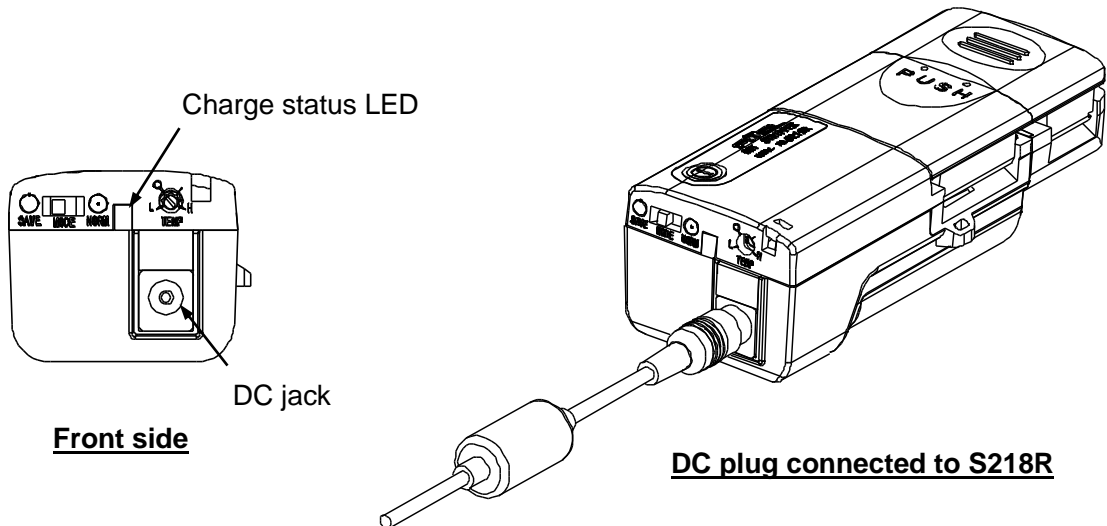

6 Operating Instruction

- 1) Connect to a power source with appropriate wiring (DC/DC converter only) and press power switch. The Indication Lamp (LED) lights red to indicate power is being supplied to the S218R-200.
- 2) The LED color will change from red to green approximately 15 seconds later to indicate that the S218R-200 is warmed up and ready to use.
- 3) Hold the fiber with a fiber holder, with approximately 30mm (25 – 35mm) of fiber end protruding from the holder. Open the Holder clamp lid and the Heater lid, and place the fiber holder firmly in the Holder clamp.
- 4) Ensure that the fiber rests in the heating area and the fiber end is within Min. and Max. line of the Heater. Refer to the drawing.

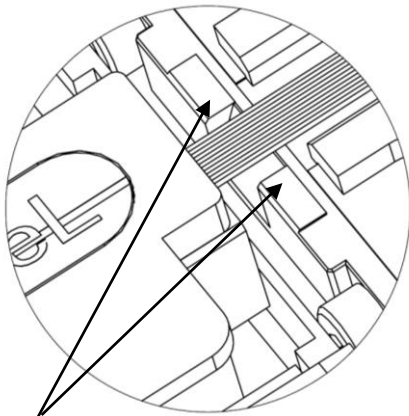

This part is not a blade.
Make sure the fiber is not riding
on this part.

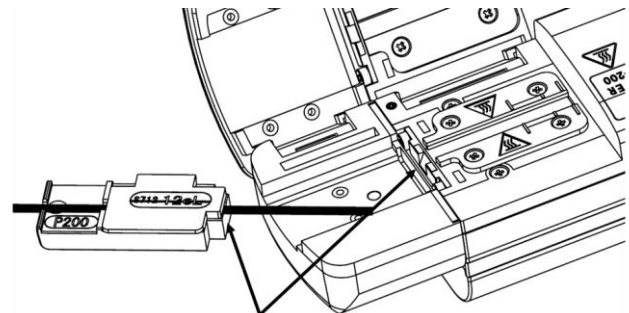

Make sure that both sides overlap

Set the fiber on the heater

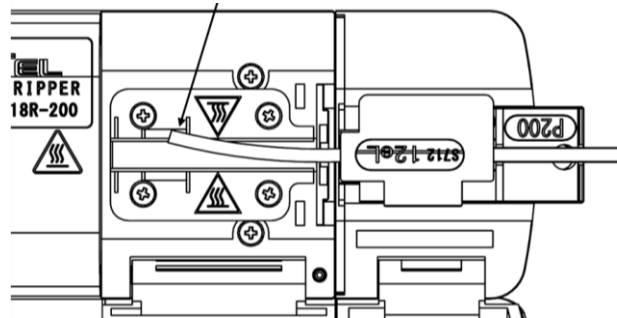

- 5) Close the Heater's lid first, and then the Holder clamp lid.
- 6) Firmly grasp the Heater lid and the Holder clamp's lid, and wait until flashing of the indication LED stops. Then, pull the holder clamp away from the Heater slowly.
- 7) Open the Holder clamp lid and the Heater lid and remove the fiber holder.
- 8) Remove coating material refuse from the Heater and clean the heating area.

CAUTION : Do not touch the Heater.

- 9) When finishing to working of S218R-200, press power switch again.



If not used the S218R-200 will auto power off after 10 minutes. (Auto Power OFF)

7 Adjusting temperature

The temperature can be changed by rotating temperature trimmer. (Refer to right drawing.)
Each scale shows 20 degree C step.
The factory setting is "H".

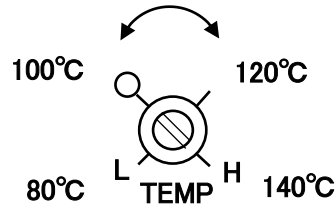

8 Setting power save mode

Save mode saves consumption of electrical power.
The mode is set to Normal mode at shipping.
The mode can be changed by setting mode switch to "SAVE" position.

In the save mode, S218R-200 cuts heater power and reduces the power consumption to a few mA during the waiting time.
So it will take more time to raise the heater temperature enough for use after leaving in this mode for a few minutes.

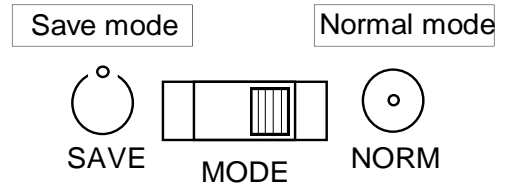

9 Recharging Battery

Attach S944 battery to the S218R-200 and charge it using S952 AC adapter.

10 Confirming Battery Remaining

During using S218R-200 with S944 battery, continuing to press the power switch for more than 2 seconds will cause the S218R to show the battery power remaining with indication lamp. (Green/Red LED)
Each state of LED shows the condition of the battery and remaining power as per following table.

Remaining (%)	100	90	70	20
State of LED	Green	Green Blinking	Red Blinking	Red

If remaining power becomes less than 10%, the LED will blink even during using.

11 Maintenance

As a routine maintenance procedure, please clean the blade and heater area by using the brush or air-blow gun periodically.

If there are some dusts or residue remaining in the blade and heater area, stripping process may not be smooth. As a result, the operation may fail.

12 Replacing the blade

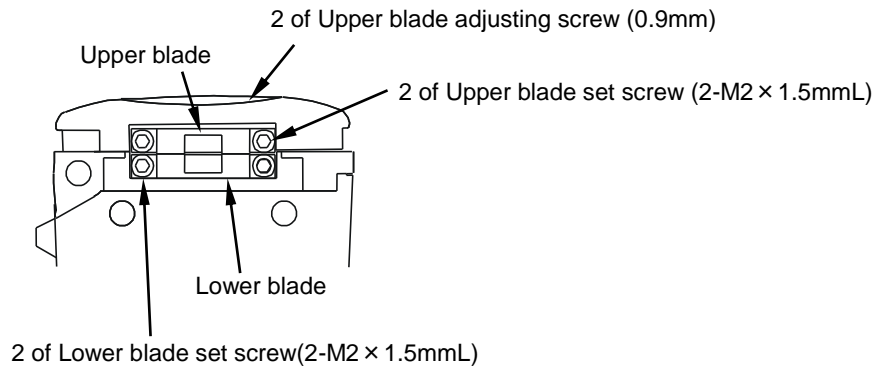

12.1 Replacing the lower blade

- 1) Remove two lower blade set screws, and take off the lower blade.
- 2) Set the new lower blade temporarily with the set screw tightened slightly.
Blade can be adjusted manually with light touch behind body.
- 3) Pushing down the lower blade to the bottom frame and fix it by means of tighten the set screw while pushing the blade downward. Use torque wrench and tighten the screw with 1.2Kg·cm.
****Take care not to over-tighten the set screw.**
- 4) After fixing, make sure of that there is no clearance between main frame and blade.

Fix the blade by tightening the set screw while pushing the blade downward.

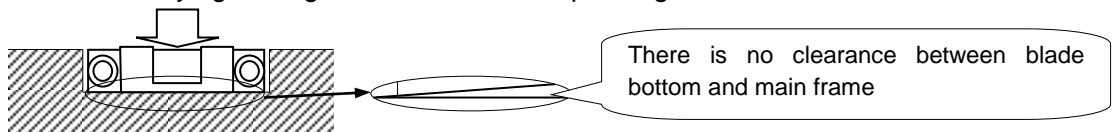

* Blade position cannot be adjusted if the set screw is over-tightened at fixation as number 2).

12.2 Replacing the upper blade

- 1) Loosen two upper blade adjusting screw with attached 0.9mm hex wrench.
Do not remove the screw, only loosen it.
- 2) Remove two upper blade set screws, and take off the upper blade.
- 3) Set the new lower blade tentatively with the set screw tightened slightly.
Blade can be adjusted manually with light touch behind body.

12.3 Upper blade adjustment

- 1) On the above condition, close the lid and tighten the two upper blade adjustment screws gradually while pressing firmly on the PUSH portion of the lid. Tighten both sides screw alternately until the full length of upper blade tip touches lower blade tip.
The clearance between lid and body is approximately 0.1mm
Refer to the next page illustration.
- 2) Set the upper blade by tightening the set screw while pressing firmly on the PUSH portion of the lid. Use the torque wrench and tighten the screw with 1.2Kg·cm.

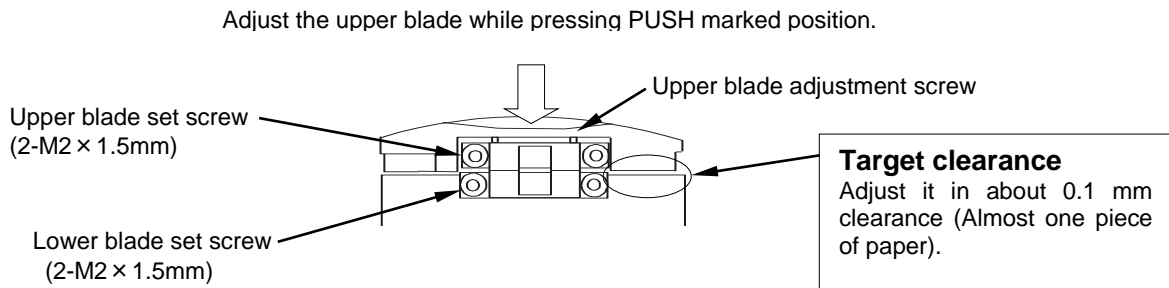

- * Same blade shape as upper blade and lower blade.
- * Both blades should be replaced at the same time.

13 Others

13.1 Mounting the Stand (Optional parts) for the unit

- 1) Remove the Battery cover.
- 2) Put the stand to the unit, then tighten the screw.

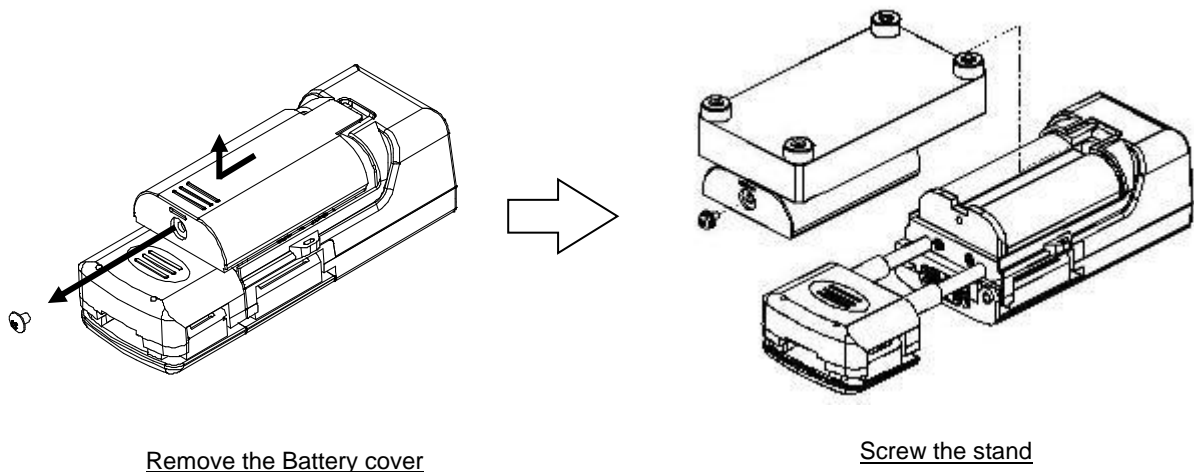

13.2 Storage for the S944 Battery Pack

If S944 Battery Pack needs to be stored for more than 1 month without being used, please store it using the following procedure.

- 1) Remove the S944 Battery Pack from S218R-200 Main body, then move that to proper storage area.
- 2) Maintain the storage environment under following conditions, temperature: -20°C to +20°C, and humidity: 15 to 95 %RH without condensing.
- 3) Charge the Battery approximately 30 minutes every 6 months.
(Caution: If the Battery is over discharge, it may be unusable.)

14 Holding period for spare parts

We will have and hold the spare parts for repair and replacement at least 6 years after these products are discontinued for production. During the period, we will repair this product.

Beyond the period, we may be able to repair this product depending on the problems, please contact Furukawa electric Co., LTD or your local sales representative for further assistant.

15 Contacts

***For sales and service information,
contact FURUKAWA ELECTRIC CO.,LTD.
or your local representative.***

2-3 Marunouchi 2-chome, Chiyoda-ku, Tokyo, 100-8322 Japan

Global Sales & Marketing

Furukawa Electric Co., Ltd.

TEL : +81-3-3286-3253 FAX : +81-3-3286-3978